



OWNER'S manual

XWOLF700 XWOLF700L
XWOLF550 XWOLF550L

READ THIS MANUAL CAREFULLY
It contains important safety information
This ATV should not be ridden by
anyone under 16 years of age.

FOREWORD

Thanks for purchasing XWOLF550、XWOLF700. This manual includes important safety information. It provides information about special techniques and skills necessary to ride this vehicle. It also includes the details to operate and necessary maintenance procedure to perform safely.

EVAP System (Evaporative Emission Control System)

Do not modify the EVAP system. Modification is a violation of EPA regulations. Ensure that all the hoses are not clogged or kinked; otherwise it could damage the fuel pump or distort the fuel tank.

IMPORTANT SAFETY MESSAGE:

- PAY ATTENTION TO THE CAUTION AND WARNING LABELS ON THIS ATV.
- READ, UNDERSTAND, AND FOLLOW ALL OF THE INSTRUCTIONS AND SAFETY PRECAUTIONS IN THIS MANUAL AND ON ALL PRODUCT LABELS. FAILURE TO FOLLOW THE SAFETY PRECAUTIONS COULD RESULT IN SERIOUS INJURY OR DEATH.
- THE ENGINE EXHAUST GAS FROM THIS PRODUCT CONTAINS CARBON MONOXIDE, WHICH IS A DEADLY GAS AND COULD CAUSE HEADACHES, GIDDINESS, LOSS OF CONSCIOUSNESS, OR EVEN

DEATH.

- READ THIS MANUAL BEFORE OPERATING THIS ATV. MAKE SURE YOU UNDERSTAND ALL INSTRUCTION. ALSO KEEP ALL INFORMATION IN MIND WHILE OPERATING THIS ATV.
- ANYONE UNDER AGE 16 SHOULD NEVER BE ALLOWED TO OPERATE ATV.
- KEEP THIS MANUAL IN THE WATERPROOF PLACTIC BAG AND STORED IN THE COMPARTMENT PROVIDED BY YOUR ATV.
- FAILURE TO FOLLOW THE WARNINGS CONTAINED IN THIS MANUAL CAN RESULT IN SERIOUS INJURY OR DEATH.

IMPORTANT NOTICE TO PARENTS AND ADULTS

- THIS ATV IS NOT A TOY.
- YOU SHOULD UNDERSTAND THE INSTRUCTIONS AND WARNINGS IN THIS MANUAL BEFORE YOU LET YOUR CHILD RIDE THIS ATV. THEN BE SURE YOUR CHILD UNDERSTANDS AND WILL FOLLOW THEM.
- THIS ATV SHOULD ONLY BE OPERATED UNDER THE DIRECT SUPERVISION OF AN ADULT.
- NEVER EXCEED YOUR RIDING CAPABILITIES.
- THIS ATV CAN BE HAZARDOUS TO OPERATE, AVOID EXCESSIVE SPEED, PAVED SURFACES,

SHARP TURNS, AND UNEVEN TERRAIN.

- THE THROTTLE SHOULD BE ADJUSTED TO A SLOWER SPEED TO ADAPT.
- ADULTS SHOULD ADJUST THE THROTTLE FOR SLOWER SPEEDS.
- NEVER RIDE THIS ATV DURING LOW LIGHT CONDITIONS.
- CHILDREN DIFFER IN SKILLS. SOME CHILDREN MAY NOT BE ABLE TO OPERATE AN ATV SAFELY.
PARENTS SHOULD PERMIT CONTINUED USE ONLY IF THEY DETERMINE THAT THE CHILD HAS THE ABILITY TO OPERATE THE ATV SAFELY.
- IF YOUR CHILD IS INEXPERIENCED IN RIDING ATV, HE OR SHE SHOULD TAKE A TRAINING COURSE BEFORE OPERATING THIS ATV.

Whenever you see the symbols shown below, heed their instructions. Always follow safe operation and maintenance practices.

WARNING

HAZARD

Failure to heed WARNINGS.

WHAT CAN HAPPEN

WARNINGS identify special instructions or procedures which, if not correctly followed, could result in serious injury or death.

HOW TO AVOID THE HAZARD

Read all WARNINGS in this manual carefully and for your safety be sure to follow their instruction.

CAUTION

This caution symbol identifies special instruction or procedures which, if not strictly observed, could Result in damage to or destruction of equipment.

NOTE

This note symbol indicates points of particular interest for more efficient and convenient operation.

FAILURE TO FOLLOW THE WARNINGS CONTAINED IN THIS MANUAL CAN RESULT IN SERIOUS INJURY OR DEATH.

⚠ WARNING FOR TYPE I ATVs

(1-person vehicle)

Improper vehicle use can result in SEVERE INJURY or DEATH



ALWAYS USE
AN APPROVED
HELMET AND
PROTECTIVE
GEAR



NEVER USE
ON PUBLIC
ROADS



NEVER CARRY
PASSENGERS



NEVER USE
WITH DRUGS
OR ALCOHOL

WARNING FOR TYPE II ATVs

(II-person vehicle)

Improper vehicle use can result in SEVERE INJURY or DEATH



ALWAYS USE
AN APPROVED
HELMET AND
PROTECTIVE
GEAR AND
PASSENGER



NEVER USE
ON PUBLIC
ROADS



NEVER CARRY
MORE THAN 1
PASSENGER



NEVER USE
WITH DRUGS
OR ALCOHOL

NEVER:

- Operate without proper training or instruction.
- Operate on public roads. A collision can occur with another vehicle.
- Operate at speeds too fast for your skill or the conditions.
- Carry multiple passengers; Type II ATVs are designed for a single passenger only.
- Use ALCOHOL or DRUGS before or while driving this vehicle.

ALWAYS:

- Avoid paved surfaces, which may adversely affect the handling and control.
- Use proper riding techniques to avoid vehicle overturn on hills and rough terrain, and when turning.
- Wear eye protection, helmet and protective clothing.

IMPORTANT NOTICE

Off-road vehicle riding is a wonderful sport, and we hope you will enjoy it to the fullest.

This vehicle is designed and manufactured for off-road use only. It is illegal and unsafe to operate this vehicle on any public road, street and highway.

Read this manual carefully and completely before starting your new ATV

It contains important safety information. Never operate this ATV without proper instruction. Beginner should take a training course before operating this vehicle.

Never allow a child under the age 16 to operate this ATV. Use of this ATV by children under 16 years of age can lead to severe injury or death of the child. Even youths starting at age 16 may not have the skills, abilities, or judgment needed to operate this ATV safely. Therefore youths starting at age 16 should have adult supervision even after they attend a training course.

To protect your safety, make sure you use your vehicle legally, show concern for the environment, and respect the rights of other people.

This Operator's Guide has been prepared to acquaint the owner/operator of a new vehicle with the various vehicle controls, maintenance and safe operating instructions. It is indispensable for the proper use of the product.

The information contained in this document is correct at the time of publication. However, LX maintains a policy of continuous improvement of its products without imposing upon itself any obligation to install them on products previously manufactured. Due to late changes, some differences between the manufactured product and the descriptions and/or specifications in this guide may occur. LX reserves the right at any time to discontinue or change specifications, designs, features, models or equipment without incurring any obligation upon itself. This Operator's Guide should remain with the vehicle when it is sold.

TABLE OF CONTENTS

SAFETY INFORMATION.....	1-1	Brake pedal	4-34
LOCATION OF THE WARNING AND		Foot Brake Reservoir Fluid Level Check	
SPECIFICATION LABELS.....	2-1	4-34
DESCRIPTION AND VEHICLE		Front and rear carriers	4-35
IDENTIFICATION	3-1	Fuel Tank	4-37
Identification number records	3-1	Seat	4-43
Vehicle identification number	3-1	Drive select lever.....	4-46
Description of the vehicle parts.....	3-4	Cig Lighter and USB Outlet.....	4-47
CONTROL FUNCTIONS	4-1	PRE- OPERATION CHECKS.....	5-1
Cig Lighter	4-1	Pre-Ride Inspection Check List	5-1
Main switch.....	4-2	Brakes.....	5-6
Handlebar switches	4-12	Fuel.....	5-7
Right Hand Controls.....	4-25	Engine Oil	5-7

Switches	5-7	Pre-operation checks	7-6
Fittings and Fasteners	5-8	Loading and accessories.....	7-8
Tires	5-8	Never exceed the stated load capacity for this ATV.....	7-9
OPERATION	6-1	During operation	7-10
Starting a cold engine	6-1	Exhaust system.....	7-11
Operating the drive select lever and driving in reverse	6-4	Be careful where you ride	7-12
Engine break-in	6-7	Turning you ATV	7-16
Parking	6-7	Climbing uphill	7-18
Loading	6-8	Riding downhill.....	7-23
RIDING YOUR ATV	7-1	Crossing a slope.....	7-25
Operator safety.....	7-1	Crossing through shallow water.....	7-27
Know your ATV before riding	7-2	Riding over rough terrain	7-29
Ride with care and judgment.....	7-2	Sliding and skidding.....	7-30
Apparel	7-3	What to do of if	7-32

What to do.....	7-32
PERIODIC MAINTENANCE AND ADJUSTMENT	8-1
Owner's manual and tool kit	8-1
Periodic maintenance chart for the emission control system	8-2
General maintenance and lubrication chart.....	8-4
Engine Oil.....	8-11
Final gear oil.....	8-17
Cooling System.....	8-20
Checking plug.....	8-24
To check the spark plug	8-25
To install the spark plug	8-26
Air filter cleaning.....	8-27

Valve clearance adjustment	8-31
Spark Arrester	8-31
Shift Lever	8-35
Belt Drive Transmission (CVT)	8-37
Brakes.....	8-39
Cable inspection and lubrication.....	8-42
Wheel removal.....	8-42
Wheel installation	8-42
Replenishing the battery	8-43
Fuse replacement.....	8-43
Troubleshooting charts	8-44
CLEANING AND STORAGE	9-1
Cleaning	9-1
Storage	9-3
Transporting the ATV.....	9-4

SPECIFICATION	10-1
EMISSION RELATED COMPONENTS	
WARRANTY	11-1
Emission related components warranty	11-1
Your warranty rights and obligations .	11-1
Manufacturer's warranty coverage....	11-1
Owner's warranty responsibilities	11-2
Warranty coverage.....	11-3
To obtain warranty service.....	11-4
Exclusions and limitations.....	11-5
Limited liability	11-5
California emission control warranty statement.....	11-8
Your warranty rights and obligations .	11-8

Manufacturer's warranty coverage ...	11-9
Owner's warranty responsibilities.....	11-9
Warranty coverage	11-11
To obtain warranty service	11-12
Exclusions and limitations	11-13
Limited liability.....	11-14

SAFETY INFORMATION

AN ATV IS NOT A TOY AND CAN BE HAZARDOUS TO OPERATE. An ATV handles differently from other vehicles including motorcycle and cars. A collision or rollover can occur quickly, even during routine maneuvers such as turning and driving on hills or over obstacles, if you fail to take proper precautions.

SEVERE INJURY OR DEATH can result if you do not follow these instructions:

- Read this manual and all labels carefully and follow the operating procedures described.
- Never operate an ATV without proper instruction. Take a training course. Beginners should receive training from a certified instructor.
- Never allow a child under age 16 to operate ATV without adult supervision, and never allow continued use of an ATV by a child if he or she does not have the abilities to operate it safely.
- Never operate an ATV on any public road, street or highway, even dirt or gravel one.
- Never consume alcohol or drugs before or while operating this ATV.
- Never operate an ATV without wearing an approved motorcycle helmet that fits properly. You should also wear eye protection (face shield or goggles), gloves, boots, long-sleeved shirt or jacket, and long pants.
- Always avoid operating an ATV on any paved surfaces, including driveways, sidewalks, streets

and parking lots.

- Always go slowly and be extra careful when operating on unfamiliar terrain. Always be alert to changing terrain conditions when operating the ATV.
- Always follow proper procedures for turning as described in this manual. Practice turning at low speeds before attempting to turn at faster speeds. Do not turn at excessive speed.
- Never operate on excessively rough, slippery or loose terrain until you have learned and practiced the skill necessary to control the ATV on such terrain. Always be especially cautious on these kinds of terrain.
- Always keep both hands on the handlebars and both feet on the footrests of the ATV during operation.
- Always inspect your ATV each time you use it to make sure it is in safe operating condition. Always follow the inspection and maintenance procedures and schedules described in this manual.
- Never attempt wheelies, jumps, or other stunts.
- Never operate at speeds too fast for your skills or the conditions. Always go at a speed that is proper for the terrain, visibility and operating conditions, and your experience.
- Never exceed the stated load capacity for an ATV. Cargo should be properly distributed and securely attached. Reduce speed and follow instructions in this manual for carrying cargo or

pulling a trailer. Allow greater distance for braking.

- Never modify an ATV through improper installation or use of accessories.
- Never operate the ATV on hills too steep for the ATV or for your abilities. Practice on smaller hills before attempting larger hills.
- Always follow proper procedures for climbing hills as described in this manual. Check the terrain carefully before you start up any hill. Never climb hills with excessively slippery or loose surfaces. Shift your weight forward. Never open the throttle suddenly or make sudden gear changes. Never go over the top of a hill at high speed.
- Always use the size and type tires specified in this manual. Always maintain proper tire pressure as described in this manual.
- Never attempt to operate over large obstacles, such as large rocks or fallen trees. Always follow proper procedures when operating over obstacles as described in this manual.
- Always use proper procedures if you stall or roll backwards when climbing a hill. To avoid stalling, use proper gear and maintain a steady speed when climbing a hill. If you stall or roll backwards, follow the special procedure for braking described in this manual. Dismount on the uphill side or to a side if pointed straight uphill. Turn the ATV around and remount, follow the procedure described in this manual.
- Always be careful when skidding or sliding. Learn to safety control skidding or sliding by

practicing at low speeds and on level, smooth terrain. On extremely slippery surface, such as ice, go slowly and be very cautious in order to reduce the chance of skidding or sliding out of control

- Never operate an ATV in fast flowing water or in water deeper than the recommended in this manual. Remember that wet brakes may have reduced stopping ability. Test your brakes after leaving water. If necessary, apply those several times to let friction dry out the linings.
- Always follow proper procedures for going down hills and for braking on hills as described in this manual. Check the terrain carefully before you start down any hill. Shift your weight backward. Never go down a hill at high speed. Avoid going down a hill at an angle that will cause the ATV to lean sharply to one side. Go straight down the hill where possible.
- Always follow proper procedures for crossing the side of a hill as described in this manual. Avoid hills with excessively slippery or loose surface. Shift your weight to the uphill side of the ATV. Never attempt to turn the ATV around on any hill until you have mastered the turning technique described in this manual on level ground. Avoid crossing the side of a steep hill if possible.
- Always check for obstacles before operating in a new area

WARNING

POTENTIAL HAZARD

Operating this vehicle without proper instruction.

WHAT CAN HAPPEN

The risk of an accident is greatly increased if the operator does not know how to operate this vehicle properly in different situations and on different types of terrain.

HOW TO AVOID THE HAZARD

Beginners and inexperienced operators should complete a training course.

They should then regularly practice the skills learned during the course as well as the operating techniques described in this Operator's Guide.

For more information about a training course, contact an authorized dealer.

WARNING

POTENTIAL HAZARD

Improper handling of gasoline.

WHAT CAN HAPPEN

Gasoline can catch and you could be burned.

HOW TO AVOID THE HAZARD

Always shut down the engine while refueling. Do not refuel immediately after the engine has been running and is still very hot. Do not spill gasoline on the exhaust muffler/pipe or engine when refueling. Never refuel while smoking, or while in the vicinity of sparks, open flames, or other sources of ignition such as the pilot lights of clothes dryers or water heaters.

When transporting the ATV in another vehicle, make sure it is placed upright and its fuel cock is in the “OFF” position. Otherwise, gasoline may leak out from the fuel tank or carburetor.

WHAT CAN HAPPEN

Gasoline is poisonous and can cause injuries.

HOW TO AVOID HAZARD

If you swallow some gasoline or breathe a lot of gasoline vapor, or get some gasoline into your eyes, see your doctor right away. If gasoline spills on your skin, wash with water and soap immediately. If gasoline spills on your clothes, change your clothes immediately.

 **WARNING**

POTENTIAL HAZARD

Improperly operating in reverse.

WHAT CAN HAPPEN

You could hit an obstacle or person behind the vehicle, resulting in serious injury.

HOW TO AVOID THE HAZARD

When you select reverse gear, make sure there are no obstacles or people behind the vehicle. When it is safe to proceed, go slowly. On 2-UP models, take account that the passenger can obstruct your view.

 **WARNING**

POTENTIAL HAZARD

Starting or running the engine in a closed area.

WHAT CAN HAPPEN

Exhaust smokes are poisonous and may cause people unconsciousness and death within a short time.

HOW TO AVOID THE HAZARD

Always start and operate your ATV in an area with adequate ventilation

WARNING

POTENTIAL HAZARD

Operating this vehicle through deep or fast flowing water.

WHAT CAN HAPPEN

Tires may float, causing loss of traction and loss of control, which could lead to an accident

HOW TO AVOID THE HAZARD

Never operate this vehicle in fast flowing water or in deep water.

Check water depth and current before you attempt to cross any water. Water should not go above footrests.

Remember that wet brakes may have reduced stopping ability. Test your brakes after leaving water. If necessary, apply those several times to let friction dry out the pads.

WARNING

POTENTIAL HAZARD

Overloading this vehicle, carrying or towing cargo improperly.

WHAT CAN HAPPEN

Could cause changes in vehicle handling which could lead to an accident.

HOW TO AVOID THE HAZARD

Never exceed the stated load capacity for this vehicle including operator as well as other loads and added accessories.

Cargo should be properly distributed and securely attached.

Reduce speed when carrying cargo or pulling a trailer. Allow greater distance for braking.

Always follow the instructions in this Operator's Guide for carrying cargo or pulling a trailer.

LOCATION OF THE WARNING AND SPECIFICATION LABELS

All warning labels which are on your vehicle are repeated here. Read labels on your vehicle and understand them thoroughly. They contain information which is important for your safety and the safety of anyone else who may operate your vehicle. Therefore, it is very important that all warning labels be on your vehicle in the locations shown. If any label is missing, damaged, or worn, get a replacement from your dealer and install it in the correct position.

NOTE

- **The sample warning labels in this section have part numbers to help you and your dealer obtain the correct replacement.**
 - **Refer to the actual vehicle label for model specific data grayed out in the illustration.**
-

XWOLF700、XWOLF700L

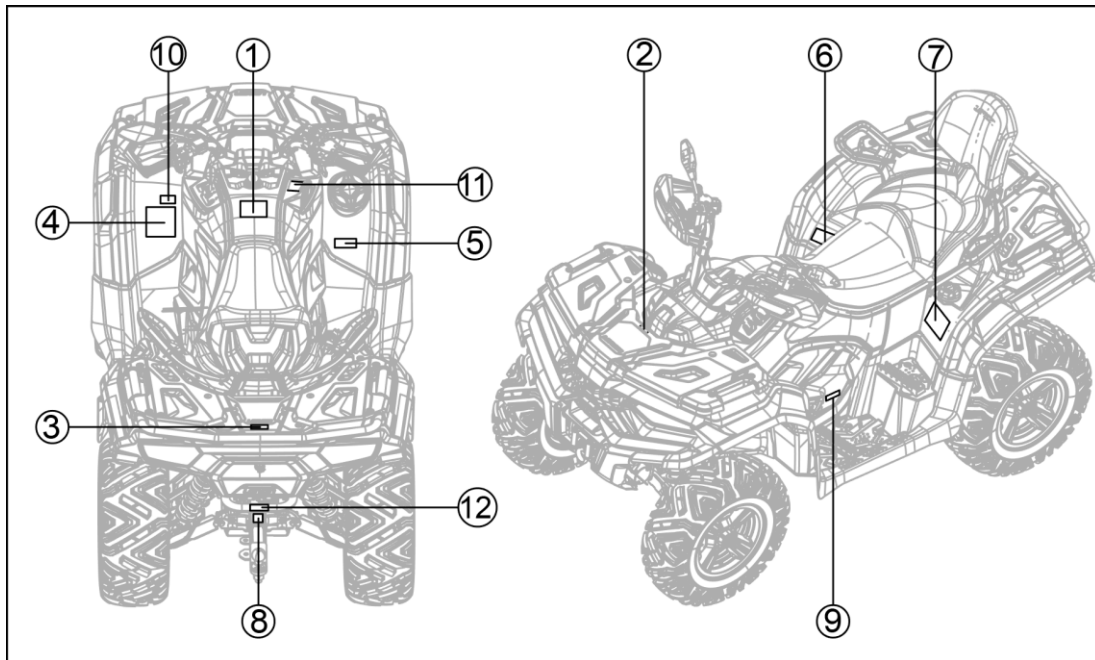

XWOLF550、XWOLF550L

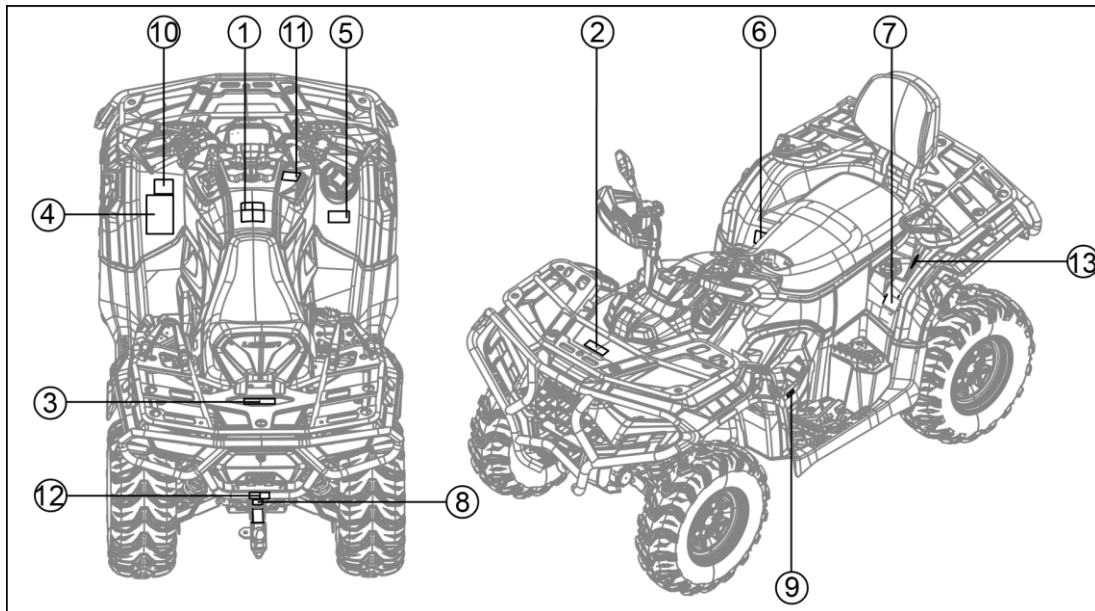

① TYPE I

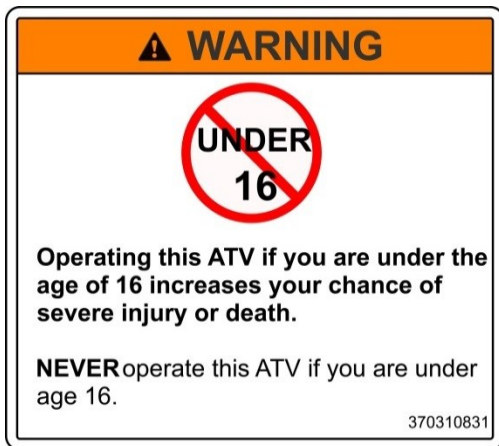

TYPE II



②



③

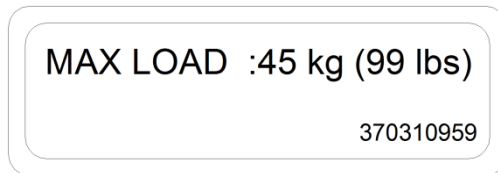

④ . TYPE I

⚠ WARNING

Improper ATV use can result in SEVER INJURY or DEATH

			
---	---	---	---

ALWAYS USE AN APPROVED HELMET AND PROTECTIVE GEAR	NEVER USE ON PUBLIC ROADS	NEVER CARRY PASSENGERS	NEVER USE WITH DRUGS OR ALCOHOL
---	---------------------------------	---------------------------	---------------------------------------

NEVER operate:

- without proper training or instruction.
- at speeds too fast for your skills or the conditions.
- on public roads-a collision can occur with another vehicle.
- with a passenger-passengers affect balance and steering and increase risk of losing control.

ALWAYS:

- use proper riding techniques to avoid vehicle overturns on hills and rough terrain and in turns.
- avoid paved surfaces-pavement may seriously affect handling and control.





**LOCATE AND READ OWNER'S MANUAL
FOLLOW ALL INSTRUCTIONS AND WARNINGS.**

370310828

TYPE II

⚠ WARNING

Improper ATV use can result in SEVER INJURY or DEATH

			
---	--	---	---

ALWAYS USE AN APPROVED HELMET AND PROTECTIVE GEAR	NEVER USE ON PUBLIC ROADS	NEVER CARRY MORE THAN 1 PASSENGERS	NEVER USE WITH DRUGS OR ALCOHOL
---	---------------------------------	--	---------------------------------------

NEVER operate:

- without proper training or instruction.
- at speeds too fast for your skills or the conditions.
- on public roads-a collision can occur with another vehicle.
- with a passenger-passengers affect balance and steering and increase risk of losing control.

ALWAYS:

- use proper riding techniques to avoid vehicle overturns on hills and rough terrain and in turns.
- avoid paved surfaces-pavement may seriously affect handling and control.
- reduce speed and use extra caution at all times when carrying a passenger-dismount passenger when conditions require.
- make sure passenger reads and understands this label and passenger safety label.

**LOCATE AND READ OWNER'S MANUAL
FOLLOW ALL INSTRUCTIONS AND WARNINGS.**

370310956

⑤.TYPE I



TYPE II

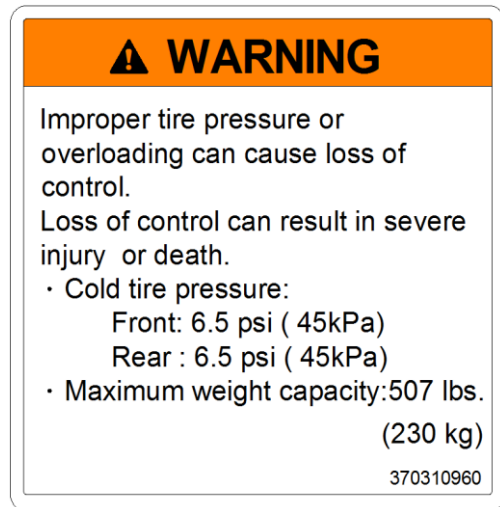

⑥ TYPE I

⚠ WARNING

Improper tire pressure or overloading can cause loss of control.

Loss of control can result in severe injury or death.

- Cold tire pressure:
 - Front: 6.5 psi (45kPa)
 - Rear : 6.5 psi (45kPa)
- Maximum weight capacity:340 lbs.
(155 kg)

370311050

TYPE II

⚠ WARNING

PASSENGER SAFETY

To reduce the risk of SEVERE INJURY or DEATH.



NEVER CARRY
MORE THAN 1
PASSENGERS



NEVER USE
WITH DRUGS
OR ALCOHOL

NEVER carry a passenger too small to firmly plant feet on footrests and securely grasp hand holds.

THE PASSENGER MUST **ALWAYS:**

- use an approved helmet and protective gear.
- securely grasp hand holds and plant feet firmly on footrests while seated in the passenger seat.
- tell operator to slow down or stop if uncomfortable-get off and walk if conditions require.

370310958

⑦

IMPORTANT DRIVE BELT INFORMATION

Neglect, abuse, or failure to maintain the transmission can result in belt damage and failure.

Inspection of the transmission drive belt is required at least every 2000 km (1200 mi) or year of use whichever comes first, since drive belts wear with normal use.

More frequent inspection is necessary if the vehicle is subjected to hard usage. If excessive belt slippage occurs, do not ride the vehicle until damaged components are repaired, Refer to your Owner's Manual.

370310833

⑧

⚠ WARNING

Improperly loading a trailer may cause loss of control. Evenly balance the load .

- Maximum towing weight



1000kg
(2205 lbs)

- Maximum tongue weight



47kg
(104 lbs)

370311200

⑨

NOTICE

Check engine oil every 500 kilometers.

370310962

⑩

NOTICE

Vehicle must be stopped before shifting transmission. Shifting while moving may result in transmission damage.

370310834

⑪

▲ WARNING

Turning the vehicle in 4WD-LOCK ("DIFF.LOCK") takes more effort.

Operate at a slow speed and allow extra time and distance for maneuvers to avoid loss of control.

370310961

⑫



▲ WARNING

NEVER attach here or on the luggage rack to pull a load.

This can cause the vehicle to tip over. ALWAYS use the trailer hitch or the recovery hook to pull a load.

370310977

13

  Bleifreies Benz in 
Unleaded fuel only
Car bur ant sans plomb
Gasol ina sin plomo
Bezolovn atý ben zin
Endas t blyfri ben zin
RON/ROZ min. **95**

370311228

DESCRIPTION AND VEHICLE IDENTIFICATION

Identification number records

Record the vehicle identification number and engine number in the follow spaces provided for assistance when ordering spare parts from your dealer or for reference in case the ATV is stolen.

1. Vehicle Identification Number:

2. Engine Number

Vehicle identification number

The vehicle identification number is stamped into the frame. This vehicle identification number is used to identify your ATV.

The engine number ① is stamped on the left side of the engine case below the cylinder.

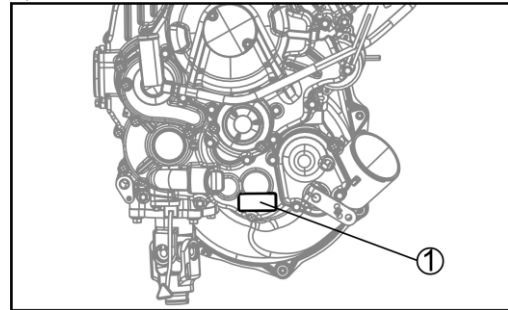

The frame number ① is stamped at the right side frame between the back wheels.

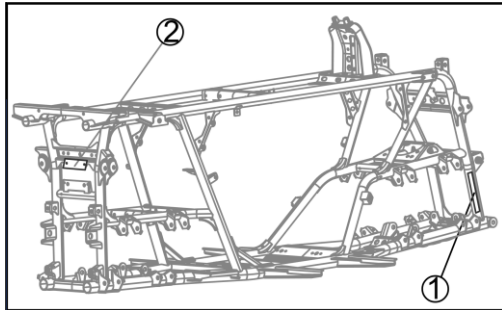

The VIN number ② is on the upper right behind the frame.

(1) If equipped

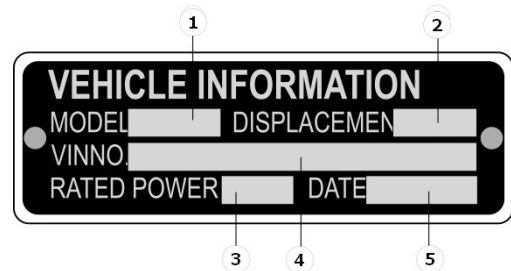

1. Vehicle type
2. Engine displacement
3. Rated power
4. VIN
5. Date of manufacture

(2) If equipped

VEHICLE INFORMATION

TYPE OF VEHICLE: ALL TERRAIN VEHICLE
Chongqing Loncin Motor Co., Ltd. certifies this ATV complies with ANSI / SVIA-1-2017 Standard.

The vehicle is designed and manufactured for the off road use only and is not equipped or approved for operation on public streets, roads or highways.

This ATV is subject to Vitacci Motorcycles, Inc's Action Plan approved by U.S. Consumer Products Safety Commission.

1 MODEL DISPLACEMENT 4

VINNO. 5

2 RATED POWER DATE 6

- 1. Vehicle type
- 2. Rated power
- 3. Regulations
- 4. Engine displacement
- 5. VIN
- 6. Date of manufacture

(3) If equipped

CHONGQING LONGCIN MOTOR CO., LTD.

T ## 1

e9*167/2013* ### 2

3

kg 4

A-1 : ### kg 5

A-2 : ### kg 6

	T-1	T-2	T-3
B-1	###kg		
B-2			

- 1: Category
- 2: Type-approval number
- 3: VIN
- 4: Permissible maximum laden mass (est.) of the vehicle
- 5-6: Permissible maximum mass (est.) per axle
- B-1: Permissible towable mass on rear coupling point; unbaked trailer

Description of the vehicle parts

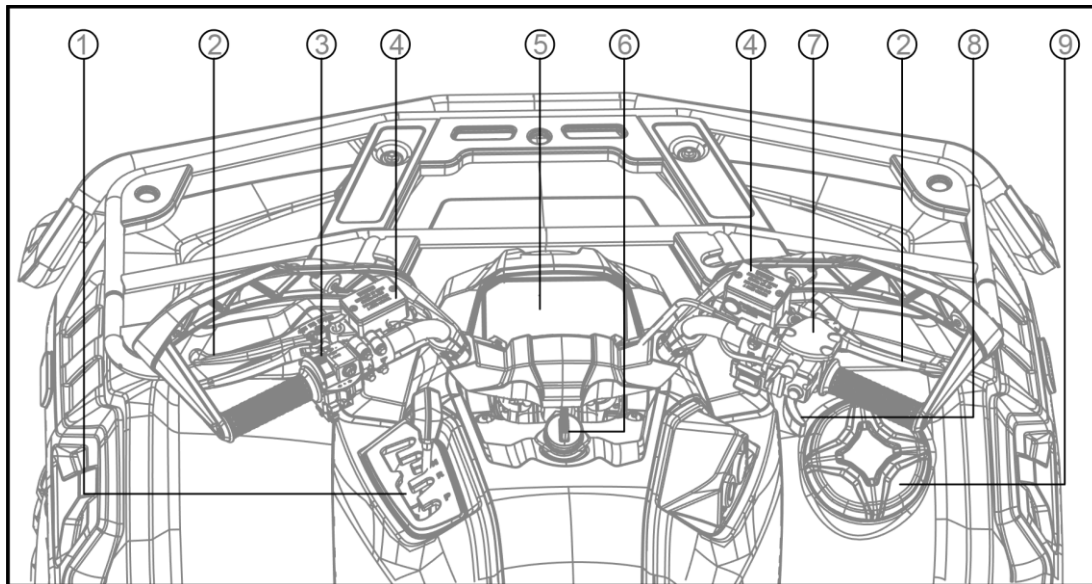

- ① Drive select lever
- ② Front brake lever
- ③ Handlebar switches

- ④ Front brake reservoir
- ⑤ Multifunction Meter
- ⑥ Main switch

- ⑦ Throttle limiter
- ⑧ Throttle lever
- ⑨ Fuel tank cap

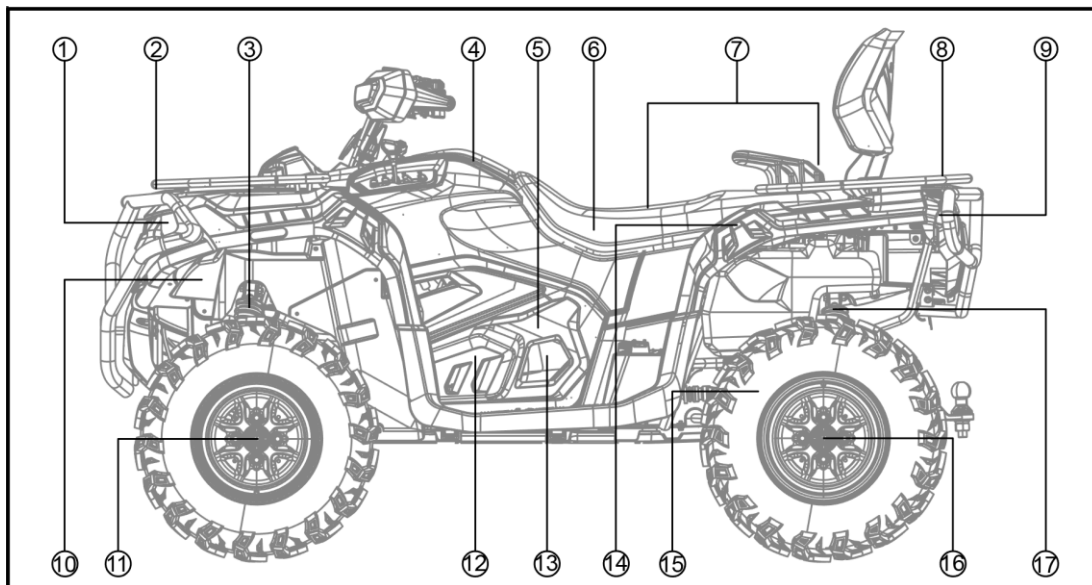

- ① Headlights
- ② Front Carrier
- ③ Front Shock Absorbers
- ④ Air Cleaner
- ⑤ Spark Plug
- ⑥ Start Relay / Battery

- ⑦ Seat
- ⑧ Rear Carrier
- ⑨ Brake/Tail Light
- ⑩ Radiator Comp.
- ⑪ Front Disc Brake Calipers
- ⑫ Engine

- ⑬ Belt Drive Transmission (CVT)
- ⑭ Fuel tank cap
- ⑮ Rear Final Gear Case
- ⑯ Rear Disc Brake Caliper
- ⑰ Rear Shock Absorber
- ⑱ Trailer power socket

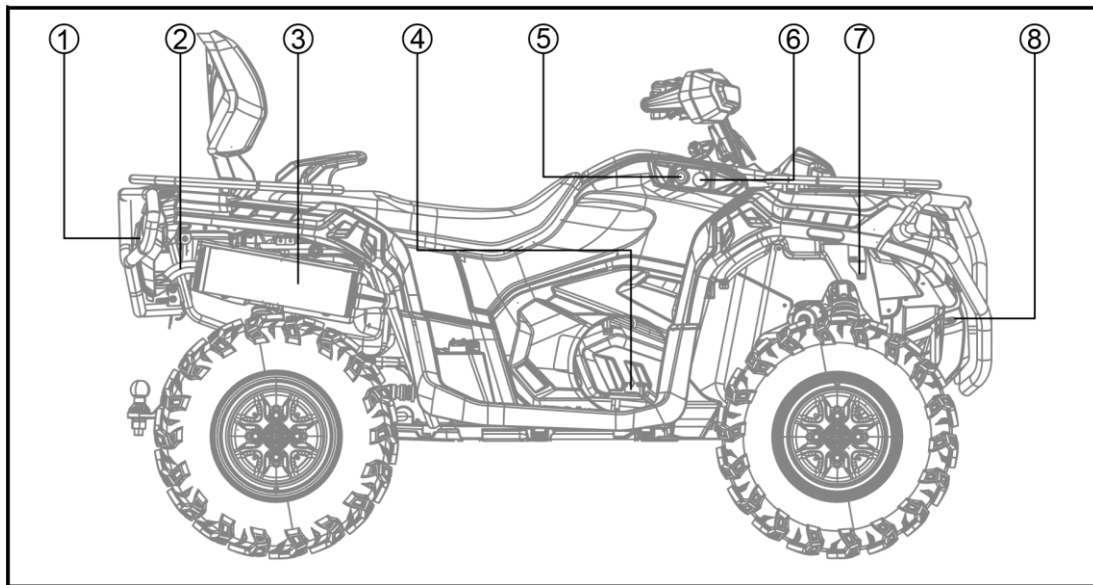

- ① Tool Kit
- ② Spark arrester
- ③ Muffler (Spark Arrester)

- ④ Brake pedal
- ⑤ USB
- ⑥ Cig lighter

- ⑦ Coolant reservoir
- ⑧ Winch (if equipped)

CONTROL FUNCTIONS

WARNING

WARNING indicates a potential hazard that could result in serious injury or death.

Cig Lighter

The power outlet connector is located under the right handlebar.

The ignition switch also operates the power outlet circuit and this vehicle has an accessory fuse (20 A) to protect this circuit.

The connector has a cap. Remove it to connect an electrical accessory.

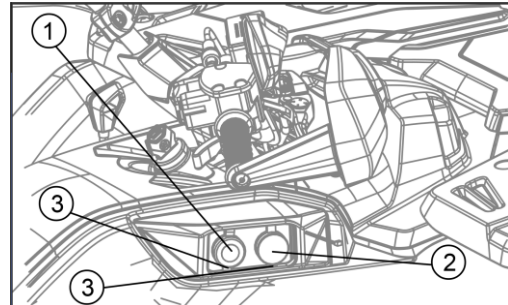

1. USB

2. Cig Lighter

3. Cap

NOTICE

Do not connect an electrical accessory rated higher than 120 W, or the battery may become discharged.

Main switch

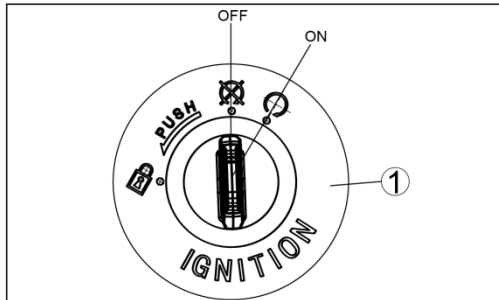

1、 Main switch

TIP

While the key is turned to "ON", the engine fault light/oil pressure indicator light/EPS indicator light will light up and remain on.

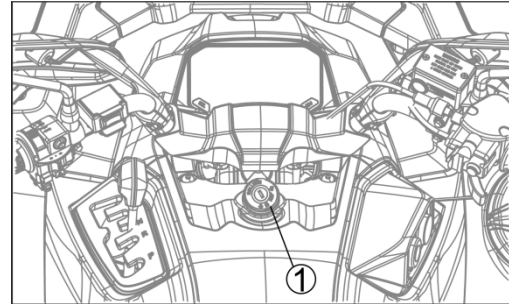

1.Main switch

Functions of the respective switch positions are as follows:

1. OFF “” :

All electrical circuits are switched off. The key can be removed in this position.

2. ON “” :

The engine can be started only at this position.

Multifunction Meter

XWOLF700、XWOLF700L

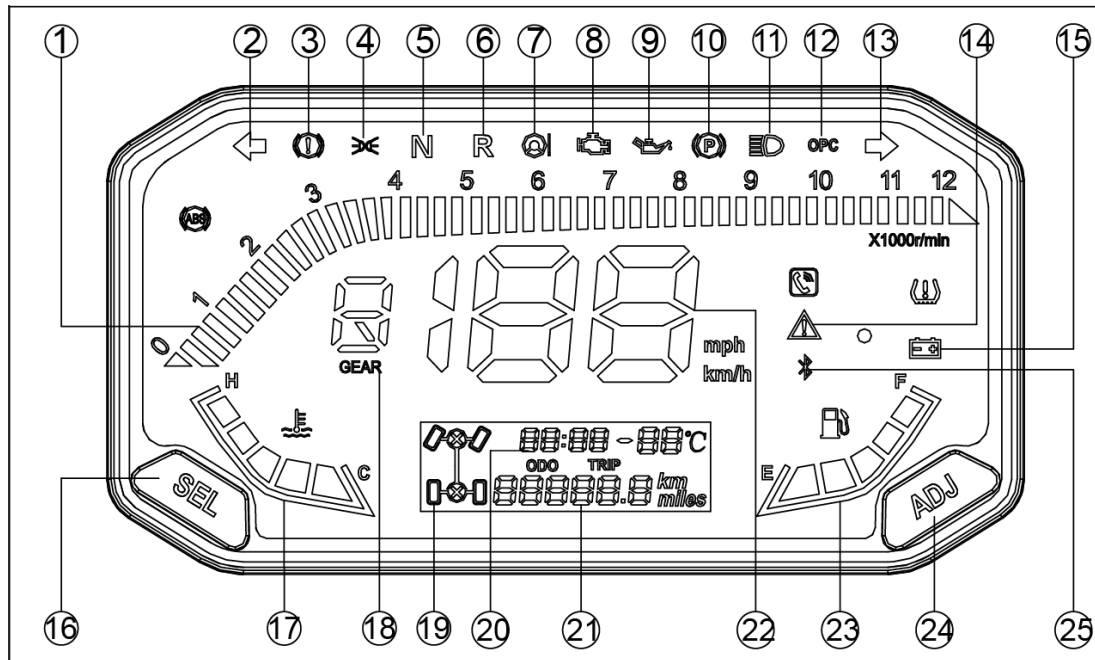

1	Engine RPM	10	Parking brake indicator	19	Drive mode
2	Turning light, LH	11	High beam indicator	20	Clock
3	Brake fluid alarm	12	OPC Indicator	21	Rider Information Center
4	Position light indicator	13	Turning light, RH	22	Speedometer
5	Neutral indicator	14	Override indicator	23	Fuel gauge
6	Reverse indicator light "R"	15	Voltmeter alarm	24	ADJ-mode adjust button
7	EPS fault indicator	16	SEL - mode select button	25	Bluetooth indicator
8	EFI fault indicator	17	Coolant Temperature		
9	Oil pressure indicator	18	Gear position indicator		

XWOLF550、XWOLF550L

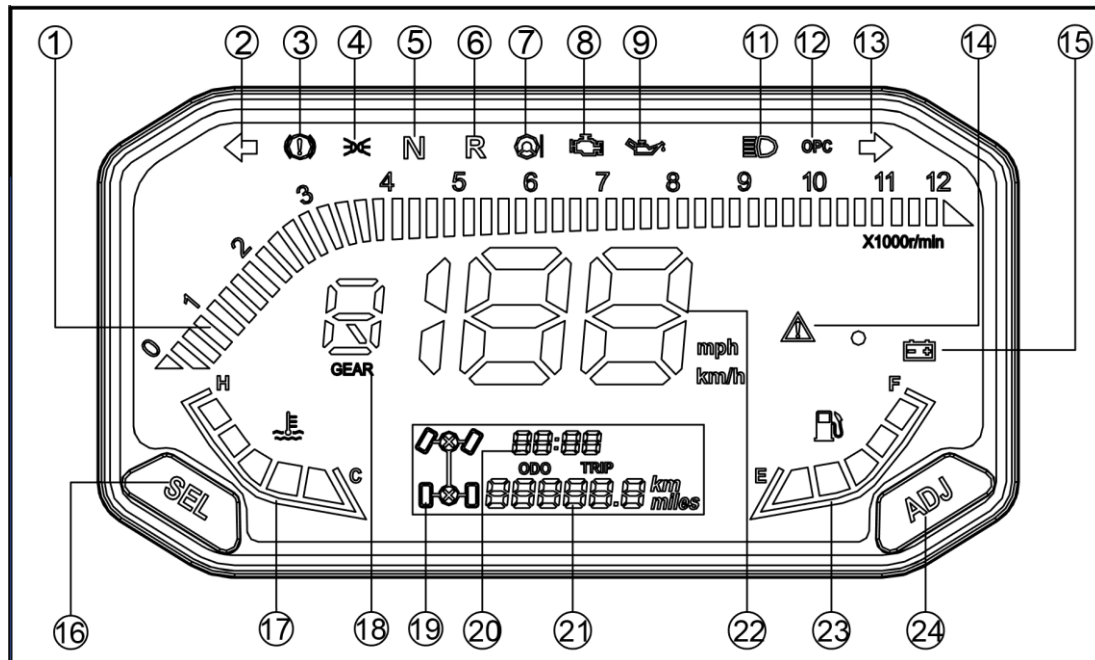

FEATURES & CONTROLS

1	Engine RPM	11	High beam indicator	20	Clock
2	Turning light, LH	12	OPC Indicator	21	Rider Information Center
3	Brake fluid alarm	13	Turning light, RH	22	Speedometer
4	Position light indicator	14	Override indicator	23	Fuel gauge
5	Neutral indicator	15	Voltmeter alarm	24	ADJ-mode adjust button
6	Reverse indicator light "R"	16	SEL - mode select button		
7	EPS fault indicator	17	Coolant Temperature		
8	EFI fault indicator	18	Gear position indicator		
9	Oil pressure indicator	19	2WD/4WD indicator		

1. Engine RPM

Indicate the engine current RPM, keep the RPM away from the red area.

2. Turning light, LH

When switch turns to left turning light position, the indicator is on.

3. Brake fluid alarm.

4. Position light indicator

This indicator illuminates when the light switch turns to position light.

5. Neutral indicator

This indicator displays when the transmission is in neutral.

6. Reverse indicator light "R".

Display the current gear position.

7. EPS fault indicator.

This indicator displays when a fault

occurs in the Electronic Power Steering system. Please stop the vehicle and contact your dealer to eliminate the fault.

8. EFI fault indicator.

This indicator displays when a fault occurs in the Electronic Fuel Injection system. Please stop the vehicle and contact your dealer to eliminate the fault.

9. Oil pressure indicator.

The oil pressure indicator is on when the oil pressure is very low. Please have your vehicle stopped safely at once when the indicator is on, inspect and eliminate the fault.

10. Parking brake indicator (If equipped)

This indicator displays when parking brake function is activated.

11. High beam indicator.

This indicator illuminates when the

headlight switch turns to high beam position.

12. OPC Indicator

Occupant Presence Control. This indicator displays if the driver left vehicle without parking. Buzzer will sound at the same time.

13. Turning light, RH

When switch turns to right turning light position, the indicator is on.

14. Override indicator

When the emergency button is pressed, the emergency indicator light comes on.

15. Voltmeter alarm

When the voltage is lower than 12.2V, the light is on.

16. SEL - mode select button

Use this button together with the “ADJ” button to adjust functions on the dashboard. Refer to “Dash board

Navigation / Settings / Adjustments”

17. Coolant Temperature

This dashboard section displays the current coolant temperature, “C” is low temperature, “H” is high temperature. Both over-low and over-high are abnormal. Idle the vehicle to warm the engine when it’s too cold, and park the vehicle when it’s too hot to prevent the coolant from boiling. Keep the coolant temperature in a normal range.

18. Gear position indicator

Display the current gear position

19. 2WD/4WD indicator

Display the current drive mode, there are 3 drive modes, 2WD, 4WD and 4WD-LOCK.

20. Clock

Display the current time. (This dashboard section can be adjusted to correct time by using the “ADJ” and “SEL” button.)

21. Rider Information Center

Rider Information Center. This dashboard section can be toggled using the “SEL” button to display: “TOTAL” -The odometer accumulated vehicle distance traveled in miles/kilometers, “TRIP”-The trip distance traveled, “H”-The accumulated engine run time, “P”-fault code displays when the vehicle ECU detects a fault.

22. Speedometer

Display the current vehicle speed. (Speedometer section can be toggled to display the vehicle speed in Kilometers per hour (km/h) or Miles per Hour (MPH) by the “ADJ” buttons.

23. Fuel gauge

Display the fuel level in the fuel tank.

24. ADJ - mode adjust button

Use this button together with the “SEL” button to adjust functions on the dashboard. Refer to “Dash board Navigation / Settings / Adjustments”.

25. Bluetooth indicator

This vehicle is equipped with blue tooth function. The blue tooth indicator will not light when it is not paired and connected to a phone. It will flash during pairing and connecting, and will remain on after pairing successfully and staying connected. The telephone indicator will not display when there is no call, it will flash when there is an incoming call.

Open the blue tooth function in your phone, and then connect the vehicle's blue tooth feature using your phone.



WARNING

Do not operate the vehicle while using blue tooth. Always stop the vehicle before answering a call. Distracted driving can result in an accident causing serious injury or death.

Dashboard Navigation / Settings / Adjustments

Item	Display	SEL	ADJ	Operation	Result
Odometer	TOTAL	Short press		Shift to trip	TRIP
Trip distance	TRIP	Short press		Shift to engine hour	Engine hour
			Long press	Trip resets to be zero	TRIP
Engine hour	H	Short press		Shift to fault code	P
Engine code	P	Short press		Odometer	TOTAL
unit setting	Non- time setting interface		Short press	Shift to unit setting	Switch between mph and km/h
Time setting interface	Home interface		Long press	Shift to set time	Hour setting
	Hour setting		Short press	Shift to minute setting	Minute setting
	set time	Short press		Add 1 by every press for hour	
		Long press	Save setting	Home interface	

Multifunction Meter (ABS EDITION)

XWOLF700、XWOLF700L

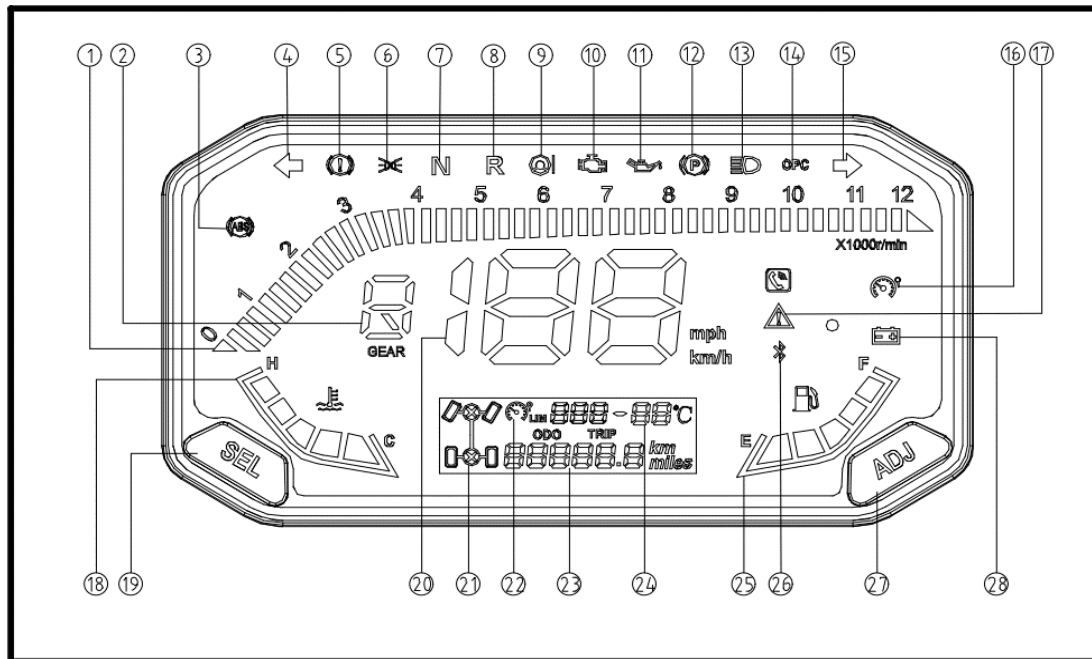

FEATURES & CONTROLS

1	Engine RPM	11	Oil pressure indicator	21	2WD/4WD indicator
2	Gear position indicator	12	Parking brake indicator	22	Speed limit indicator
3	ABS fault indicator	13	High beam indicator	23	Rider Information Center
4	Turning light,LH	14	OPC indicator	24	Environment temperature
5	Brake fluid alarm	15	Turning light,RH	25	Fuel gauge
6	Position light indicator	16	Speed limitation alarm	26	Bluetooth indicator
7	Neutral indicator	17	Override indicator	27	ADJ-mode adjust button
8	Reverse indicator light "R"	18	Coolant Temperature	28	Voltmeter alarm
9	EPS fault indicator	19	SEL-mode select button		
10	EFI fault indicator	20	Speedometer		

XWOLF550、XWOLF550L

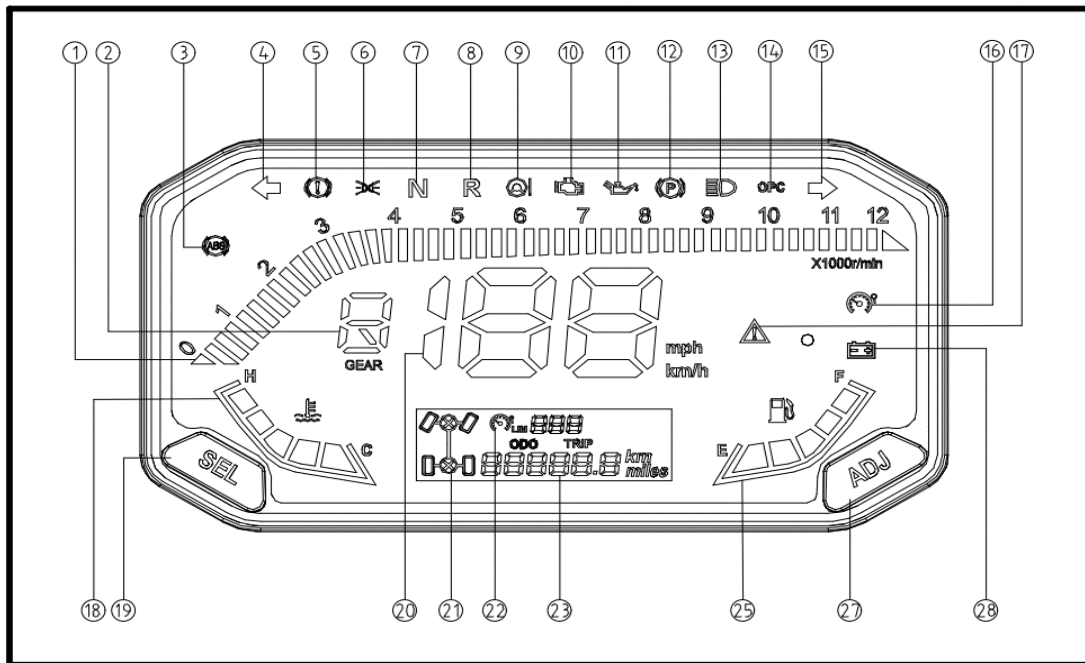

FEATURES & CONTROLS

1	Engine RPM	11	Oil pressure indicator	21	2WD/4WD indicator
2	Gear position indicator	12	Parking brake indicator	22	Speed limit indicator
3	ABS fault indicator	13	High beam indicator	23	Rider Information Center
4	Turning light,LH	14	OPC indicator	25	Fuel gauge
5	Brake fluid alarm	15	Turning light,RH	27	ADJ-mode adjust button
6	Position light indicator	16	Speed limitation alarm	28	Voltmeter alarm
7	Neutral indicator	17	Override indicator		
8	Reverse indicator light "R"	18	Coolant Temperature		
9	EPS fault indicator	19	SEL-mode select button		
10	EFI fault indicator	20	Speedometer		

1. Engine RPM

Indicate the engine current RPM, keep the RPM away from the red area.

2. Gear position indicator

Display the current gear position.

3. ABS fault indicator(If equipped)

This indicator displays when a fault occurs in the anti-lock braking system. Please stop the vehicle and contact your dealer to eliminate the fault.

4. Turning light, LH

When switch turns to left turning light position, the indicator is on.

5. Brake fluid alarm.

6. Position light indicator

This indicator illuminates when the light switch turns to position light.

7. Neutral indicator

This indicator displays when the transmission is in neutral.

8. Reverse indicator light "R".

Display the current gear position.

9. EPS fault indicator.

This indicator displays when a fault occurs in the Electronic Power Steering system. Please stop the vehicle and contact your dealer to eliminate the fault.

10. EFI fault indicator.

This indicator displays when a fault occurs in the Electronic Fuel Injection system. Please stop the vehicle and contact your dealer to eliminate the fault.

11. Oil pressure indicator.

The oil pressure indicator is on when the oil pressure is very low. Please have your vehicle stopped safely at once when the

indicator is on, inspect and eliminate the fault.

12. Parking brake indicator (If equipped)
This indicator displays when parking brake function is activated
13. High beam indicator.
This indicator illuminates when the headlight switch turns to high beam position.
14. OPC Indicator
Occupant Presence Control. This indicator displays if the driver left vehicle without parking. Buzzer will sound at the same time.
15. Turning light, RH
When switch turns to right turning light position, the indicator is on.
16. Speed limitation alarm
This indicator blinks when the speed value exceeds the speed limit.
17. Override indicator

When depress the override button, override indicator is on, 4WD-LOCK speed limitation will be released in this state.

18. Coolant Temperature
This dashboard section displays the current coolant temperature, “C” is low temperature, “H” is high temperature. Both over-low and over-high are abnormal. Idle the vehicle to warm the engine when it’s too cold, and park the vehicle when it’s too hot to prevent the coolant from boiling. Keep the coolant temperature in a normal range.
19. SEL - mode select button
Use this button together with the “ADJ” button to adjust functions on the dashboard. Refer to “Dash board Navigation / Settings / Adjustments”

20. Speedometer

Display the current vehicle speed. (Speedometer section can be toggled to display the vehicle speed in Kilometers per hour (km/h) or Miles per Hour (MPH) by the “ADJ” and “SEL” buttons.

21. 2WD/4WD indicator

Display the current drive mode, there are 3 drive modes, 2WD, 4WD and 4WD-LOCK.

22. Speed limit indicator

Display the speed limit. (The speed limit can be adjusted to what you want by using the “ADJ” button. Including lifting the speed limit)

23. Rider Information Center

Rider Information Center. This dashboard section can be toggled using the “SEL”

button to display: “TOTAL” -The odometer accumulated vehicle distance traveled in miles/kilometers, “TRIP”-The trip distance traveled,

“H”-The accumulated engine run time, “P”-fault code displays when the vehicle ECU detects a fault.

24. Environment temperature

Indicates the current environment temperature.

25. Fuel gauge

Display the fuel level in the fuel tank.

26. Bluetooth indicator

This vehicle is equipped with blue tooth function. The blue tooth indicator will not light when it is not paired and connected to a phone. It will flash during pairing and connecting, and will remain on after

pairing successfully and staying connected.

The telephone indicator will not display when there is no call, it will flash when there is an incoming call.

Open the blue tooth function in your phone, and then connect the vehicle's blue tooth feature using your phone.



Do not operate the vehicle while using blue tooth. Always stop the vehicle before answering a call. Distracted driving can result in an accident causing serious injury or death.

27. ADJ - mode adjust button

Use this button together with the "SEL" button to adjust functions on the dashboard. Refer to "Dash board Navigation / Settings / Adjustments".

28. Voltmeter alarm

When the voltage is lower than 12.2V, the light is on.

Dashboard Navigation / Settings / Adjustments

Item	Display	SEL	ADJ	Operation	Result
Odometer	TOTAL	Short press		Shift to trip	TRIP
Trip distance	TRIP	Short press		Shift to engine hour	Engine hour
			Long press	Trip resets to be zero	TRIP
Engine hour	H	Short press		Shift to fault code	P
Engine code	P	Short press		Odometer	TOTAL
unit setting	Non-rate limiting setting interface		Short press	Shift to unit setting	Switch between mph and km/h
Speed limit setting	Home interface		Long press	Open the speed limit	Speed limit adjustment

Item	Display	SEL	ADJ	Operation	Result
	Speed limit adjustment		Short press	<ol style="list-style-type: none"> 1. When the speed unit is KM/H, the cycle shifts from 30KM/H to 90KM/H. Each speed limit is increased by 10KM/H. 2. When the speed unit is mph, the cycle shifts from 20mph to 55mph. Every time you push the speed limit you increase by 5mph. Note: When the vehicle is traveling, the speed limit value will be selected from a value greater than or equal to the current speed. 	
	Speed limit adjustment		Long press	Turn off speed limit	Home interface

Handlebar switches

XWOLF700、XWOLF700L

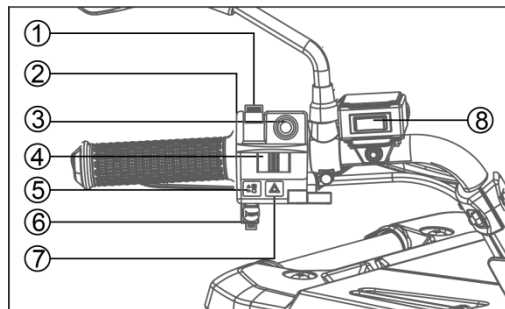

- ① Light Switch
- ② The speed limit is lifted under 4W-LOCK
- ③ Start Switch ④ Turning Light Switch
- ⑤ Engine Stop Switch ⑥ Horn Button
- ⑦ Emergency lamp switch
- ⑧ Controller switch winch

XWOLF550、XWOLF550L

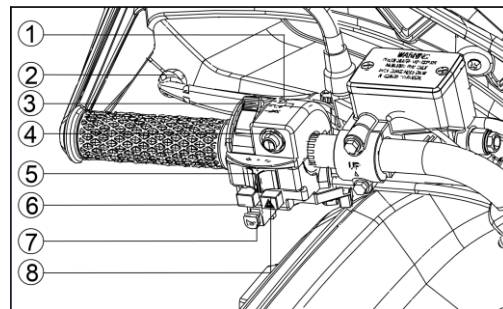

- ① Override Switch ② Rear Brake
- ③ Light Switch ④ Start Switch
- ⑤ Turning Light Switch ⑥ Engine Stop Switch
- ⑦ Horn Button ⑧ Emergency lamp switch

Light switch:

Set the switch to “” to turn on the low beam and the taillight.

Set the switch to “” to turn on the high beam and the taillight.

Set the switch to “OFF” to turn off all the lights.

Set the switch to “” to turn on the tail light license plate light and front position light.

WARNING

Do not use the headlights with the engine turned off for more than 15 minutes. The battery may discharge to the point that the starter motor will not operate properly. If this should happen, remove the battery and recharge it.

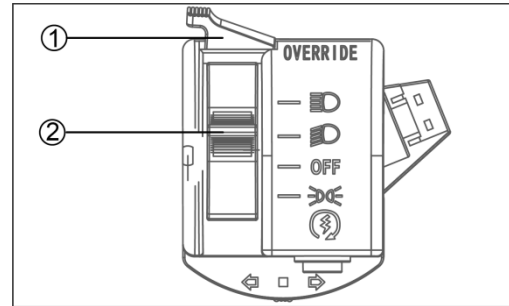

① The speed limit is lifted under 4W-LOCK (XWOLF700) ① Override Switch (XWOLF550)

② Light Switch

Top speed is normally limited when operating in differential gear lock. If conditions require more engine power when riding forward, push and hold this switch to override the differential gear lock speed limiting function. Releasing the switch restores the speed limiting function.

Start switch

Push (🔌) this switch to let the starter motor crank the engine.

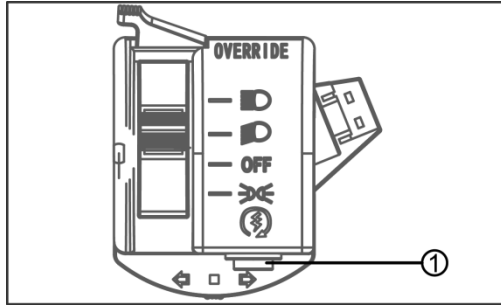

① Start Switch

NOTE: _____

If the starter switch is pushed with the main switch “ON” and the engine stop switch “OFF”, the starter motor will be activated but the engine will not start. To start the engine, make sure the engine stop switch at _____

“RUN” position.

Turning Light Switch

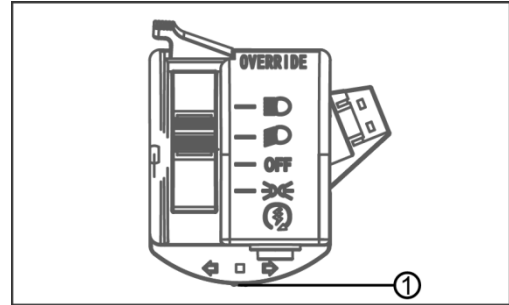

① Turning Light Switch

Turn the switch to position ⬅️, the left turn signal indicator and left turning light will be on.

Turn the switch to position ➡️, the right turn signal indicator and right turning light will be on.

Engine stop switch

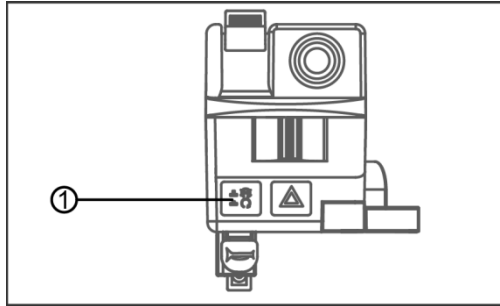

① Engine stop switch

When the switch is in the RUN (⏻) position, the engine will be operated. When the switch is in OFF (⏻) position, the engine will not operate. The engine stop switch controls ignition and can be used at all times to stop the engine, especially in an emergency. The engine will not start when this switch is in “OFF” position.

Right Hand Controls

XWOLF700、XWOLF700L

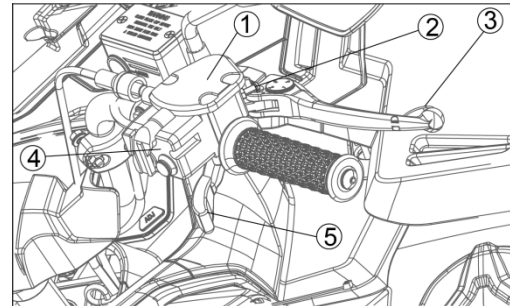

① Front Brake Fluid Reservoir and Level Indicator

② Mechanical Speed Limiter

③ Front Brake

④ Four Wheel Drive (4WD) System Switch

⑤ Throttle Lever

XWOLF550、XWOLF550L

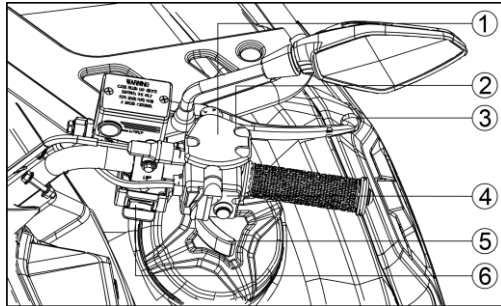

- ① Front Brake Fluid Reservoir and Level Indicator
- ② Mechanical Speed Limiter
- ③ Front Brake
- ④ Four Wheel Drive (4WD) System Switch
- ⑤ Throttle Lever
- ⑥ Controller switch winch

Front Brake Fluid Reservoir and Level Indicator

Check the front brake master cylinder fluid level before each use of the ATV. The front brake master cylinder is located on the right handlebar. The fluid level can be viewed through the indicator window on the side of the master cylinder. If the fluid level is lower than the “lower” mark, refill with brake fluid as necessary.

WARNING

An over-full master cylinder may cause brake drag or brake lockup, which could result in serious injury or death. Maintain brake fluid at the recommended level. Do not overfill.

Mechanical Speed Limiter

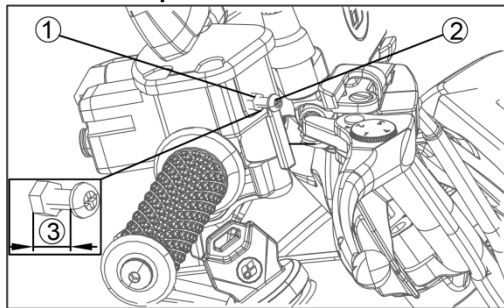

1 Locknut 2.Screw 3.13mm(0.51in)

A mechanical speed limiter keeps the throttle from fully opening, even when the throttle lever is pushed to maximum travel. Turning in the screw limits the throttle lever travel, which reduces the maximum engine power available and decreases the maximum speed of the ATV.

NOTE

Your ATV is set for maximum throttle opening from the factory.

CAUTION

Always loosen the locking nut a before each adjustment. Do not turn the adjusting screw out more than 13 mm (0.51 in). Always make sure the throttle lever free play remains adjusted to 3 mm ~ 5 mm (0.12 in ~0.20 in). Tighten the locking nut when the adjustment is completed.

Front Brake

The brake lever is located on the right handlebar. Pull the lever toward handlebar to apply the front brake. Check the free play of front brake lever. You can adjust the brake lever by turning the adjuster

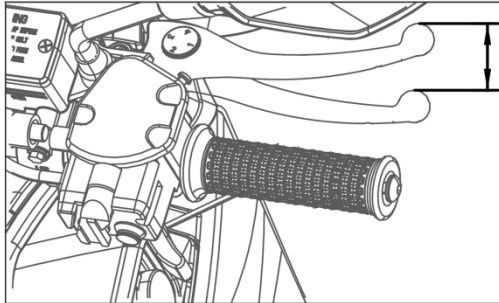

Brake lever has 4 gears to adjust, adjust the brake lever and handle clearance. From the first to the four gears the gap gradually becomes smaller

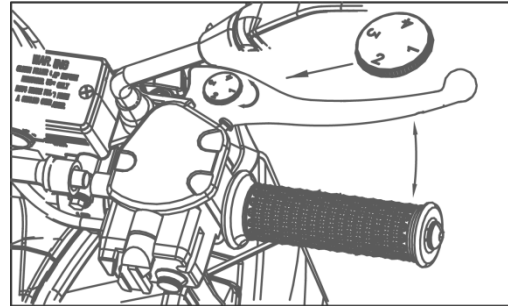

Hydraulic parking brake lever

Hydraulic parking brake is mounted on the right hand brake. To apply parking brake, grasp tightly the right hand brake first, at the same time, rotating the hydraulic parking brake lever 1 by left hand.

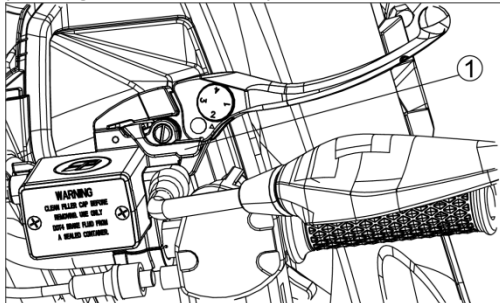

① Hydraulic parking brake lever

CAUTION

Do not to rely only on the hydraulic parking brake when parked on an incline. For additional safety, shift the transmission to the park position and block the wheels to prevent vehicle rolling.

Four Wheel Drive (4WD) System Switch

This ATV is equipped with on-command “2WD”/“4WD” and “LOCK/4WD” switches:

- Two-wheel drive (2WD): Power is supplied to the rear wheels only. The mode lever (1) is moved to the left and the switch button is outward.
- Four-wheel drive (4WD): Power is supplied to the rear and front wheels. The mode lever (1) is moved to the left and the switch button is pushed in.
- Four-wheel drive LOCK (4WD-LOCK): Power is supplied to the rear and front wheels. The mode lever (1) is moved to the right and the switch button is pushed in. The front differential is locked, so all wheels turn at the same speed

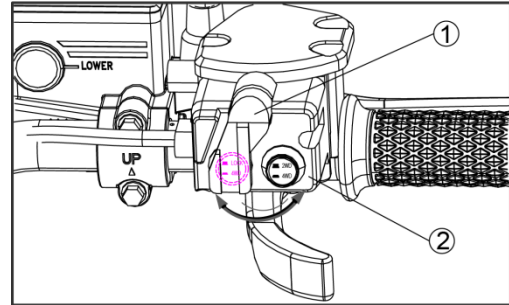

① Mode lever

② Four Wheel Drive (4WD) System Switch

NOTE:

- When switching between “2WD”/“4WD” and “LOCK/4WD” must stop. Otherwise, the container may be damaged.
- When the mode switch is set to “F-LOCK”, the indicator light “⁰⁴⁰⁷” will flash until the front differential is

locked.

- Riding before the front differential is properly engaged (e.g., when the indicator light is flashing) will cause the engine speed to be limited until engagement is complete.
 - When the ATV is in 4WD-LOCK, the maximum traveling speed is limited to 30 km/h (19 mph). If conditions require full engine power to be available, press the override switch to disable the 4WD-LOCK speed limiter.
-

Throttle Lever

The vehicle is equipped with a throttle lever to decrease maximum engine power for an unskilled operator. The limiter functions by restricting the moving distance of the throttle lever.

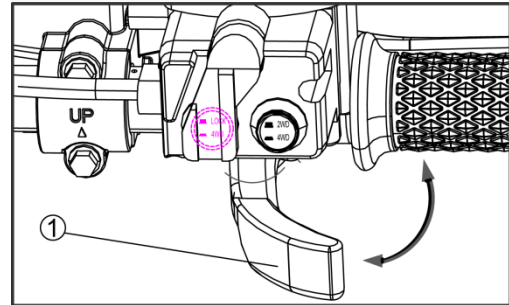

① Throttle Lever

WARNING

POTENTIAL HAZARD

Malfunction of throttle.

WHAT CAN HAPPEN

The throttle level could be hard to operate, cause it difficult to speed up or slow down when you need to. This could cause an accident.

HOW TO AVOID THE HAZARD

Always check the operation of the throttle level before you start the engine. If it doesn't work smoothly, check for the reason. Correct the problem before riding this ATV. Consult your dealer if you cannot find or solve the problem by yourself.

WARNING

HAZARD

Operating this ATV without proper instruction.

WHAT CAN HAPPEN

The risk of an accident is greatly increased if the operator does not know how to operate the ATV properly in different situations and on different types of terrain.

HOW TO AVOID THE HAZARD

Beginning and inexperienced operators should complete a certified training course offered by The ATV Safety Institute (ASI). They should then regularly practice the skills learned in the course and the operating techniques described in the Owner's Manual

 **WARNING**

HAZARD

Operating this ATV at excessive speeds.

WHAT CAN HAPPEN

Increases your chances of losing control of the ATV, which can result in an accident.

HOW TO AVOID THE HAZARD

Always go at a speed that is proper for the terrain, visibility and operating conditions, and your experience.

NOTICE

If the throttle limiter is adjusted, verify the changes in throttle in an open, non-traffic area.

Never try to adjust the limiter by racing the engine in neutral or in gear with brake on, or the engine may be damaged.

Brake pedal

The brake pedal is located on the right side of the machine. Push down the pedal to apply the rear brake. If the ATV have CBS (Combination Braking System) , Push down the pedal to apply both the front and rear brake.

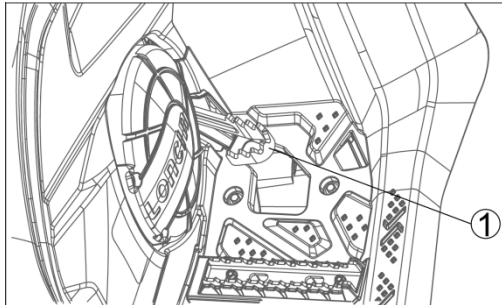

① Brake pedal

Foot Brake Reservoir Fluid Level Check

NOTE

Remove the front access cover and then check the fluid level. When checking the fluid level, the ATV must be on level ground. If fluid level is lower than the “lower” mark 1 , add DOT4 brake fluid. Don't overfill.

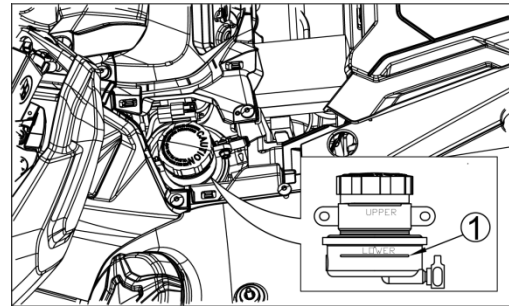

NOTICE

Never store or use a partial bottle of brake fluid. Brake fluid is hygroscopic, meaning it rapidly absorbs moisture from the air. The moisture causes the drop of boiling temperature of the brake fluid, which can lead to early brake fade and the possibility of accident or severe injury. After opening a bottle of brake fluid, always discard any unused portion.

Front and rear carriers

This vehicle is equipped with carriers on the front and rear

Maximum load

	Other	Mud plate
Front	35kg (77 lbs)	/
Rear	45kg (99 lbs)	45kg (99 lbs)

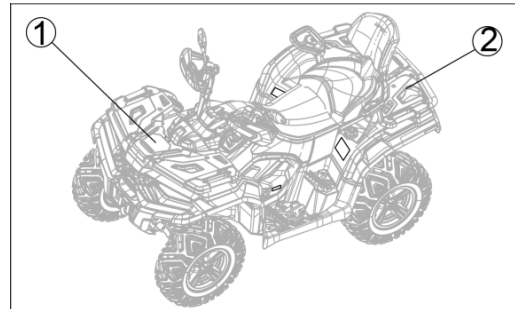

Front carriers

Rear carriers

WARNING

HAZARD

Overloading front and rear carriers or carrying cargo improperly.

WHAT CAN HAPPEN

Could cause changes in vehicle handling which could lead to an accident

HOW TO AVOID THE HAZARD

Never exceed the stated load capacity for each carrier. Cargo should be properly distributed and securely attached.

Reduce speed when carrying cargo. Allow greater distance for braking.

Always follow the instructions in your Owner's Manual for carrying cargo

Fuel Tank

Only use gasoline with the recommended octane rating. Avoid filling the tank in the rain or where heavy dust is blowing so that the fuel does not get contaminated.

Never fill the tank completely to the top. As the fuel expands in a warm tank, it may overflow from the vent hose. After refueling, make sure the filler cap is closed securely. It is the torque-limiting type to prevent over-tightening.

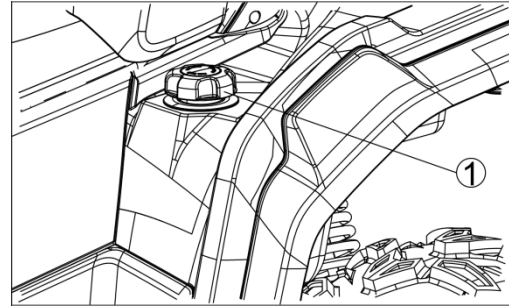

① Fuel tank filler cap

WARNING

HAZARD

Refueling without following proper precautions.

WHAT CAN HAPPEN

Gasoline is extremely flammable and can be explosive under certain conditions.

A fire or explosion can cause severe injury or death.

HOW TO AVOID THE HAZARD

When refueling, do not smoke. Turn the ignition key to "OFF". Make sure the area is well ventilated and free from any source of flame or sparks; this includes any appliance with a pilot light.

Never fill the tank completely to the top! Heat may cause gasoline to expand and overflow through the exhaust hose.

After refueling, make sure the fuel tank cap is closed securely.

If gasoline is spilled on the rear fender wipe it off immediately.

WARNING

POTENTIAL HAZARD

Overfilling the fuel tank could be hazardous.

WHAT CAN HAPPEN

If you overfill the fuel tank, fuel may overflow when it expands. Expanding is due to heat from engine or sun. Overheated fuel could easily catch fire.

Improper fueling of the ATV could be hazardous.

Failing to follow safety precautions when refueling could result in a fire or let you to breathe toxic fumes.

HOW TO AVOID THE HAZARD

Stop adding fuel when the fuel level reaches the bottom of the filler neck.

Refuel in a well-ventilated area. Make sure the engine is off and avoid spilling fuel on a hot engine. Do not smoke, and make sure there are no open flames or sparks in the area. Avoid breathing gasoline vapors. Keep children and pets away when you are refueling the ATV.

Fuel Requirements:

Fuel Type

Use clean, fresh unleaded gasoline with a minimum Antiknock Index of 87. The octane rating of a gasoline is a measure of its resistance to detonation or "Knocking." The Antiknock Index is an average of the Research Octane Number (RON) and the Motor Octane Number (MON) as shown in the table below.

Octane Rating Method	Minimum Rating
Antiknock $\frac{\text{RON} + \text{MON}}{\text{Index}}$ 2	87

NOTICE

If engine "knocking" or "pinging" occurs, use a different brand of gasoline of a higher octane rating. If this condition is allowed to continue it can lead to severe engine damage.

Gasoline quality is important. Fuels of low quality or not meeting standard industry specifications may result in unsatisfactory performance. Operating problems that result from the use of poor quality or not recommended fuel may not be covered under your warranty.

Fuels Containing Oxygenates

Gasoline frequently contains oxygenates (alcohols and ethers) especially in areas of the U.S. and Canada which are

required to sell such reformulated fuels as part of a strategy to reduce exhaust

The types and volume of fuel oxygenates approved for use in unleaded gasoline by the U.S.

Environmental Protection Agency includes a broad range of alcohols and ethers, but only two components have seen any significant level of commercial use.

Gasoline/Alcohol Blends-Gasoline containing up to 10% ethanol (alcohol produced from agricultural products such as corn), also known as "gasohol" is approved for use.

NOTICE

Avoid using blends of unleaded gasoline and methanol (wood alcohol) whenever possible, and never use "gasohol" containing more than 5% methanol. Fuel system damage and performance problems may result.

Gasoline/Ether Blends- The most common ether is methyl tertiary butyl ether (MTBE). You may use gasoline containing up to 15% MTBE

NOTICE

Never use gasoline with an octane rating lower than the minimum specified by dealers

Never use "gasohol" with more than 10% ethanol, or more than 5% methanol. Gasoline containing methanol must also be blended with solvents and corrosion inhibitors.

Certain ingredients of gasoline may cause paint fading or damage. Be extra careful not to spill gasoline or gasoline oxygenates blends during refueling.

Never store this product with in the fuel system. Before storage it is recommended that you drain all fuel from the fuel tank.

Seat

Short seat

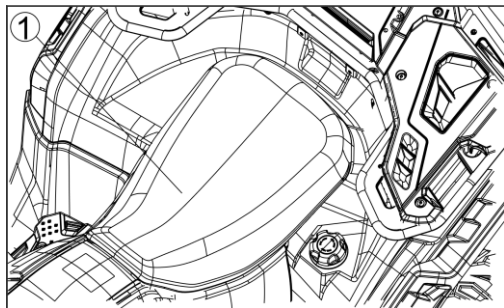

① Seat

Plus long seats (XWOLF700L)

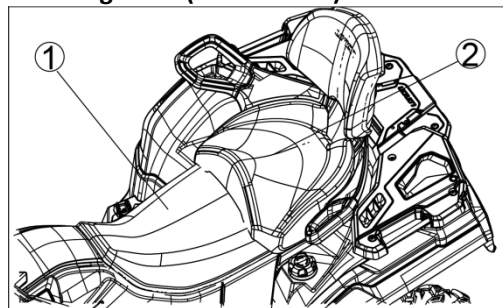

① Seat1 ② Seat2

Plus long seats (XWOLF550L)

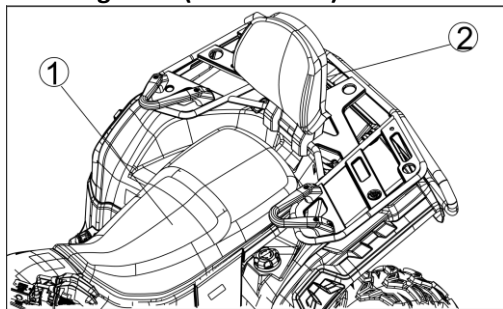

① Seat1 ② Backrest

NOTE: _____

Always make sure the seat is securely fitted.

⚠ WARNING

Improperly installing the seat could be hazardous.

Failing to install the seat properly could allow the seat to move and cause the rider to lose control.

Make sure you are in proper position and that the seat is attached securely when you ride.

Short seat

To remove the seat, First pull up one side of the seat in the back, then pull up the other side.

To install the seat, insert the projections on the front of the seat into the holder on the rear of the air filter, and push down on the seat at the rear when the locks on the rear of the seat aim at the support cushion under the seat.

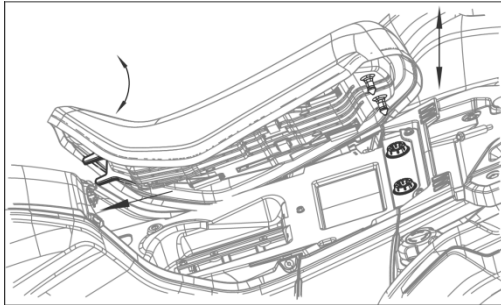

Plus long seats (XWOLF700L)

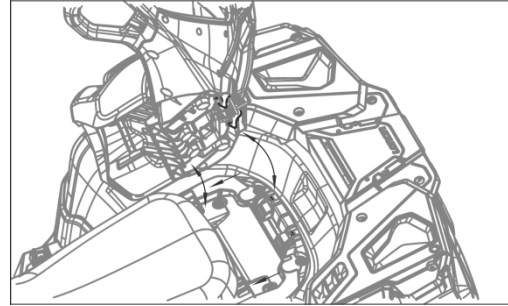

To install the seat, insert the protruding front of the seat into the rear seat frame, and then push the seat down when the latch on the back of the seat is aligned with the support tube under the seat

Backrest (XWOLF550L)

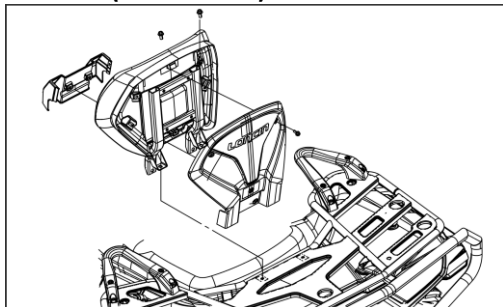

Drive select lever

The drive select lever is located on the left side of the vehicle. The drive select lever is used to shift your machine into the forward, neutral, reverse positions.

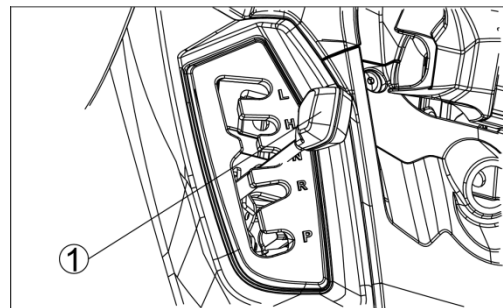

① Drive select lever

L (Low-range)

H (High-range)

N (Neutral)

R (Reverse)

P (Park positions)

NOTE: _____

Always stop the ATV and press the foot brake pedal before shifting the transmission. Shifting gears with the engine speed above idle or while the vehicle is moving could cause transmission damage. To change gears, stop the vehicle, and with the engine idling, move the lever to the desired gear. Whenever the ATV is left unattended, always place the transmission in the PARK position. Maintaining shift linkage adjustment is important to assure proper transmission function. See your dealer if you experience any shifting problems.

When a long time (more than 1 minute) at a low speed of less than 10km/h, please

stop and switch to L gear for operation.

NOTE: _____

Never depend on the parking feature alone if the ATV is parked on a hill. Always block the wheels on the down hillside of the ATV to prevent rolling. It is recommended to park the ATV on level ground.

Cig Lighter and USB Outlet

Auxiliary 12Vdc power and USB outlets are provided on the right side front fender area for operating accessories such as hand held spot lights and charging electronic devices. Please consult with your dealer on the use of powered accessories with your vehicle.

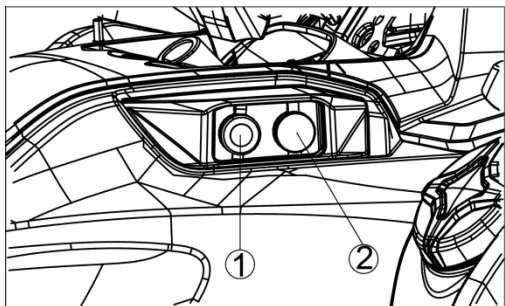

① USB

② Cig Lighter

Trailer Power Socket (if equipped)

This vehicle is equipped with trailer power socket, located under the rear cargo rack. The socket wires are configured to this standard as shown in the image provided. An accessory trailer power converter is required for trailers that do not have a connector. Contact your dealer for more information.

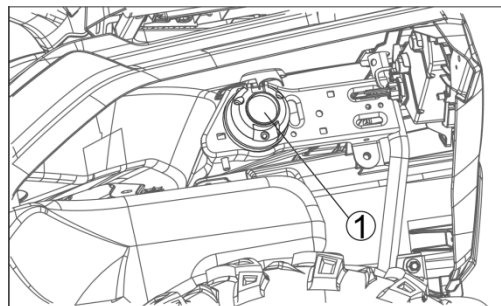

① Trailer Power Socket

Winch (if equipped)

This vehicle is equipped with a winch. The winch control is located on the left handle bar. To preserve battery power, only operate the winch when the engine is running. Please consult with your dealer on the use of the winch before using your vehicle or refer to the instructions for use of winch.

XWOLF700、XWOLF700L

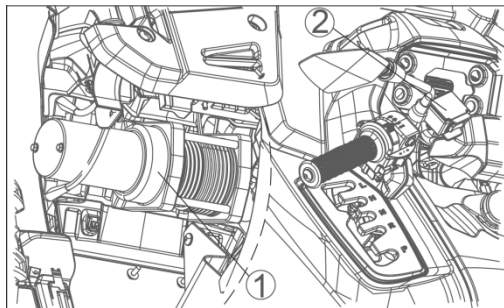

① winch

② Controller switch winch

XWOLF550、XWOLF550L

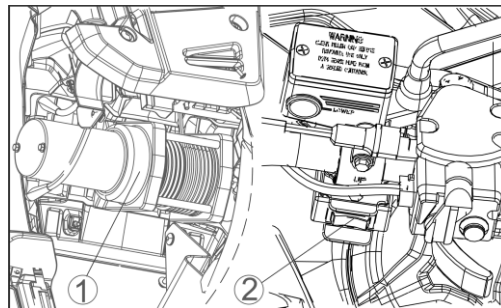

① winch

② Controller switch winch

General safety precautions regarding the use of winch

Moving part hazards

To prevent serious injury and property damage:

- Do not operate or install winch without reading and understanding these instructions and the Basic Guide to Winching Techniques.
- Keep hands clear of wire rope, hook and fairlead opening during operation and when spooling.
- Use supplied hook strap for spooling wire rope.
- Stand clear of wire rope and load during operation.
- Keep others away.
- Inspect winch installation and wire rope condition before operating winch
- Do not use as a hoist.
- Do not use to move persons.
- Do not exceed winch's rated capacity.
- Never touch wire rope or hook while in tension.
- Be certain the anchor you select will withstand load.
- Never wrap wire rope back onto itself. Use a choker chain or tree trunk protector on the anchor.
- Prior to initiating winching operation be sure any element which can interfere with safe winching is removed.
- Do not disengage clutch if winch is under load or wire rope is in tension.

- Take your time. Sloppy rigging causes accidents.
- The wire rope must always spool onto the drum as indicated by the drum rotation label on the winch.

To avoid injury and property damage:

- Do not use winch to secure a load during transport.
- Do not submerge in water.

- Do not use to tow other vehicles.
- Wear heavy leather gloves when handling the wire rope.
- Never winch with less than 5 wraps of wire rope around the drum.
- Caution should be used if the vehicle is tied down during a winching operation. This may lead to damage to the frame.

PRE- OPERATION CHECKS

Pre-Ride Inspection Check List

Before operating this ATV, be sure to check the items listed in the following table.

What to Do Before Starting the Engine (Key OFF)

ITEMS TO BEINSPECTED	INSPECTION TO PERFORM
Engine oil	Check engine oil level.
Coolant	Check coolant level.
fuel	Check fuel
Brake fluid	Check brake fluid level.
Leaks	Check for any leaks under vehicle
Throttle lever	Activate throttle lever several times to ensure it operates

ITEMS TO BEINSPECTED	INSPECTION TO PERFORM
Tires	Check tire pressure and condition. Refer to SPECIFICATIONS and adjust according to load.
Wheels	Check wheels for damage and for abnormal play, and make sure that lug nuts are tightened. Refer to WHEELS AND TIRES in MAINTENANCE PROCEDURES for torque specification.
Radiator	Check cleanliness of the radiator
Drive shaft boots	Check drive shaft boots and protectors condition
Seat(s)	Check if operator seat is in place and properly latched
	Check if passenger seat is in place and properly latched (2-UP Models)
	Check the passenger backrest and grab handles condition(2-UP Models)
Cargo	If you transport a cargo, respect the load capacity. Refer to LOADING THE CARGO RACKS

ITEMS TO BEINSPECTED	INSPECTION TO PERFORM
	<p>Ensure cargo is properly secured to the racks</p> <p>If you are pulling a trailer or another equipment:</p> <ul style="list-style-type: none"> – Check hitch and trailer ball condition – Respect the tongue capacity and towing capacity as indicated on the label affixed to the hitch or refer to SPECIFICATIONS – Ensure trailer is properly secured to hitch.
Storage compartment	Check if rear storage compartment is properly latched
Chassis and suspension	Check underneath vehicle for any debris on chassis or suspension and clean them properly
Engine air filter	Inspect and clean engine air filter

What to Do Before Starting the Engine (Key ON)

ITEMS TO BE INSPECTED	INSPECTION TO PERFORM
Multifunction gauge	Check operation of indicator lamps in multifunction gauge(during first few seconds of key ON)
	Check for messages on multifunction gauge
Lights	Check operation and cleanliness of headlights and taillight
	Check operation of low and high beams
	Check operation of brake light
	Check operation and cleanliness of turn signal lights
	Check operation of hazard lights
Horn	Check operation of the horn
Fuel level	Check the fuel level

What to do after the Engine is started

ITEMS TO BEINSPECTED	INSPECTION TO PERFORM
Steering	Check if steering operates freely by completely turning it from side to side
Shift lever	Check operation of shift lever (P, R, N, H and L)
Brakes	Drive forward slowly a few feet and apply brake lever and brake pedal individually. The brakes must fully apply. Lever and pedal must fully return when released
Engine stop switch	Check that the engine stop switch is working properly
Ignition switch	Check if ignition switch is working properly by restarting and stopping the engine

WARNING

POTENTIAL HAZARD

Failure to check the ATV before operating.

Failure to maintain the ATV properly.

WHAT CAN HAPPEN

It could cause an accident or equipment damage.

HOW TO AVOID THE HAZARD

Always check your ATV carefully each time before you use it to be sure the ATV is in safe operation condition.

Always follow inspection and maintenance procedure as shown in the owner's manual

Never allow a passenger on an ATV that is not designed for carrying a passenger

Brakes

1. Brake operation

Test the brakes at slow speed after starting to make sure they are working properly. If any of the brakes does not provide proper function, inspect the brake for wear and the level of the brake fluid.

2. Brake pedal and brake levers

Check the correct free play in the brake pedal and brake levers. Adjust it if the free play is incorrect.

Fuel

Always fill regular unleaded gasoline to your ATV. Do not use leaded gasoline; it will cause damage to internal engine parts.

If knocking or pinging occurs, use a different brand of gasoline or premium unleaded fuel.

WARNING

Do not overfill the fuel tank. Be careful not to spill fuel, especially on the engine or exhaust pipe. Make sure the fuel tank cap is closed securely.

Do not refuel right after the engine has been running and is still very hot.

Engine Oil

Always fill engine oil according to ambient temperature recommended as follows:

Ambient temperature / recommended oil:

-10°C—40°C/SAE10W-40

Make sure the engine oil is at specified level. Add oil as necessary:

XWOLF700 The specified level of the crankcase engine oil: 2300ml

XWOLF550 The specified level of the crankcase engine oil: 2500ml

Switches

Check the operation of engine stop switch, starter switch, main switch, 2W and 4W. Repair as necessary for proper operation.

Fittings and Fasteners

Always check the tightness of chassis before riding this ATV. Take the ATV to your dealer or refer to this manual for correct tightening torque.

Tires

Measure tire pressure by the tire gauge and set the front and rear tires pressure to 45kPa (6.5psi).

	XWOLF700 XWOLF700L	XWOLF550 XWOLF550L	Mud plate
Front:	25 × 8-12 26 × 9-12	25 × 8-12	27 × 9-14
Rear	25 x 10 – 12 26 × 10-12	25 x 10 - 12	27 × 11-14

WARNING

POTENTIAL HAZARD

Operating this ATV with Improper tires, or with improper or uneven tire pressure.

WHAT CAN HAPPEN

Operating this ATV with Improper tires or with improper or uneven tire pressure could cause loss of control and an accident.

HOW TO AVOID THE HAZARD

The specific tire pressure is shown on the tire.

Measuring the tire pressure

Use the low-pressure tire gauge.

NOTE: _____

Please use the low-pressure tire gauge. Make two measurements of the tire pressure and use the second reading. Dust or dirt in the gauge could cause the first reading to be incorrect.

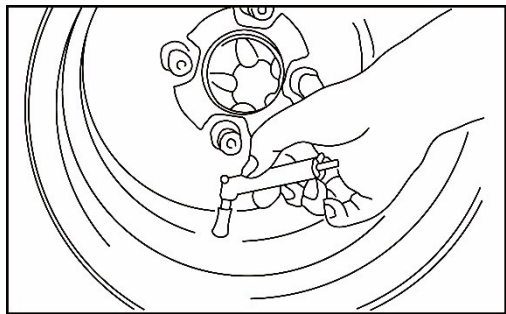

Tire wear limit

When the tire groove decreases to 3 mm (0.12 in) due to wear, replace the tire.

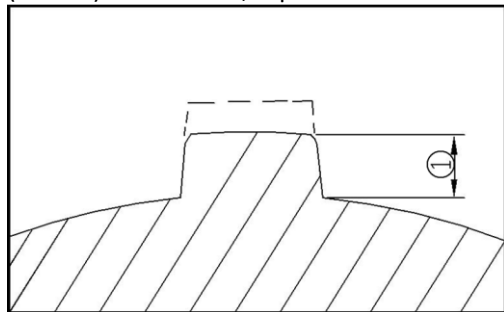

①、Tire wear limit

OPERATION

WARNING

Indicates a potential hazard that could result in serious injury or death.

WARNING

POTENTIAL HAZARD

Operating ATV without being familiar with all controls.

WHAT CAN HAPPEN

Loss of control, which could cause an accident or injury.

HOW TO AVOID THE HAZARD

Read this manual carefully. If you don't understand any control or function, ask your dealer.

Starting a cold engine

WARNING

POTENTIAL HAZARD

Frozen control cables in cold weather.

WHAT CAN HAPPEN

You could be unable to control the ATV, which could lead to an accident or collision.

HOW TO AVOID THE HAZARD

When riding in cold weather, always make sure all control cables work smoothly before you begin riding.

1. Turn the main switch to "ON" and the engine stop switch to "⊖".

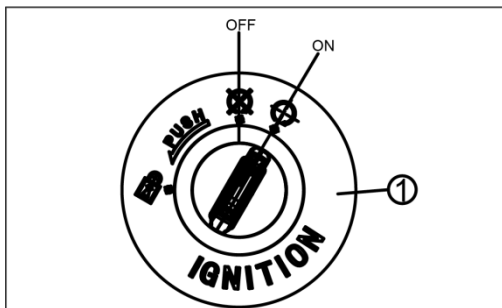

CAUTION: _____

The coolant temperature warning light and engine trouble warning light should come on, then go off. The EPS warning light should come on, then go off when the engine is started. If a warning light does not go off, have a dealer check the electrical circuit.

2. Apply the brake pedal, and then shift the drive select lever into the neutral or park position. The corresponding indicator light should come on. If a warning light does not go off, have a dealer check the electrical circuit.
3. Apply the rear brake lever or brake pedal.
4. Completely close the throttle lever and start the engine by pushing the start switch.

NOTE: _____

This model is equipped with an ignition circuit cutoff system. The engine can be started under the following conditions:

- The drive select lever is in the neutral or park position.
 - The rear brake lever or brake pedal is applied with the drive select lever in any position. However, it is recommended to shift into the neutral or park position before starting the engine.
-

NOTE: _____

Push the throttle lever to the middle position (warming up position.) Until the engine runs then release the start button. If the engine fails to start, release the start button, and then push it again. Each cranking should not be more than 5 seconds; the continuous cranking times should not be more than 3 times.

5. Continue warming up the engine until it idles smoothly.

CAUTION: _____

For maximum engine life, always warm the engine up before starting off. Never accelerate hard when the engine is cold!

Operating the drive select lever and driving in reverse

CAUTION: _____

Before shifting, stop the ATV, otherwise the transmission may be damaged.

Shifting: Neutral to High-range and High-range to Low-range

1. Bring the ATV to a complete stop.
2. Apply the brake pedal, and then shift by moving the drive select lever along the shift guide.

NOTE: _____

Make sure that the drive select lever is completely shifted into position.

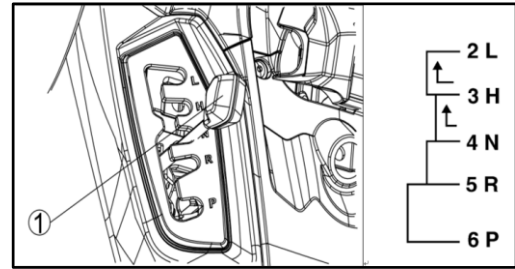

- ① Drive select lever ② L (Low-range)
③ H (High-range) ④ N (Neutral)
⑤ R (Reverse) ⑥ P (Park)

3. Release the brake pedal, and then open the throttle lever gradually.

Shifting: Neutral to Reverse and Reverse to Park

NOTE: _____

The drive select lever cannot be shifted into or from reverse or park without applying the brake pedal.

1. Bring the ATV to a complete stop.
2. Apply the brake pedal.
3. Shift from neutral to reverse or from reverse to park and vice versa by moving the drive select lever along the shift guide.

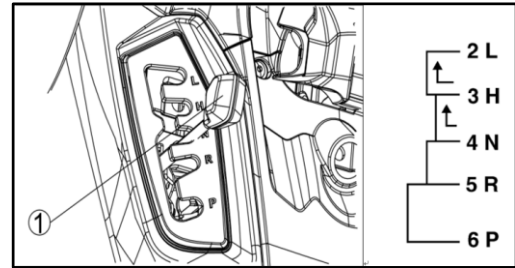

- ① Drive select lever ② L (Low-range)
③ H (High-range) ④ N (Neutral)
⑤ R (Reverse) ⑥ P (Park)

NOTE: _____

When in reverse, the reverse indicator light should come on. If the indicator light does not come on, have a dealer check the electrical circuit.

Due to the synchronizing mechanism in the engine, the indicator light may not come on until the ATV starts moving.

4. Check behind for people or obstacles, and then release the brake pedal.
5. Open the throttle lever gradually and continue to watch to the rear while backing.

 **WARNING**

POTENTIAL HAZARD

Improperly operating in reverse.

WHAT CAN HAPPEN

You could hit an obstacle or even a person behind you, resulting in serious injury.

HOW TO AVOID THE HAZARD

When you shift into reverse, make sure there are no people or obstacles behind you.

When it is safe to proceed, go slowly.

Engine break-in

There is never a more important period in the life of your engine than the first 320 km (200 mi) or 20 hours of riding. For this reason, you should read the following material carefully.

- Do not put an excessive load on the ATV for first several hours of running.
- Never continuous operation above half throttle.
- Cool off the engine for ten minutes after every hour of operation.
- Vary the speed of the engine from time to time.
- 320 km (200 mi) or 20 hours and beyond
The ATV can now be operated normally.

Parking

When parking the ATV, stop the engine, and shift the drive select lever into the park position.

WARNING

POTENTIAL HAZARD

Parking on a hill or other incline.

WHAT CAN HAPPEN

The ATV could roll out of control, increasing the chance of an accident.

HOW TO AVOID THE HAZARD

Avoid parking on hills or other inclines. If you must park on an incline, place the ATV transversely across the incline, stop the engine, shift the drive select lever to the park position, and then block the front and rear wheels with rocks or other

objects.

Don't park an ATV on a steep hill that you won't be able to climb easily.

1. Bring the ATV to a stop by applying the brakes.
2. Stop the engine.
3. With the brake pedal applied, shift the drive select lever to the park position.

Loading

The ATV can carry cargo; cargo can change the stability and handling of an ATV. You must use common sense and good judgment when carrying cargo.

WARNING

Overloading this ATV or carrying or towing cargo could cause changes in vehicle handling which could lead to an accident. Never exceed the stated loading capacity for this ATV.

Never exceed the weight limits shown. An overloaded ATV can be unstable.

Weight of operator and baggage or cargo must not exceed:	
Xwolf 700/Xwolf 700L/Xwolf 550/ Xwolf 550L:	230 kg (507lb).
Mud edition :	195 kg(430 lb).
Front carrier(Xwolf 700/Xwolf 550):	35.0 kg (77 lb)
Rear carrier: (Xwolf 700/Xwolf 550)	45.0 kg (100 lb)
Front carrier(Xwolf 700L/Xwolf 550L):	35.0 kg (77 lb)
Rear carrier: (Xwolf 700L/Xwolf 550L)	45.0 kg (100 lb)
Rear carrier(Mud edition):	45.0 kg (100 lb)
Trailer hitch:	
Pulling load (total weight of trailer and cargo):	3500 N
Tongue weight (vertical weight on trailer hitch point):	420N

WARNING

HAZARD

Operating this ATV with improper modifications.

WHAT CAN HAPPEN

Improper installation of accessories or modification of this vehicle may cause changes in handling which could lead to an accident.

HOW TO AVOID THE HAZARD

Never modify this ATV through improper installation or use of accessories. All parts and accessories added to this vehicle should be genuine dealer or equivalent components designed for use on this ATV and should be installed and used according to instructions.

If you have questions, consult an authorized ATV dealer.

WARNING

HAZARD

Overloading this ATV or carrying or towing cargo improperly.

WHAT CAN HAPPEN

Could cause changes in vehicle handling which could lead to an accident.

HOW TO AVOID THE HAZARD

Never exceed the stated load capacity for this ATV. Cargo should be properly distributed and securely attached. Reduce speed when carrying cargo or pulling a trailer. Allow greater distance for braking. Always follow the instructions provided in this section for carrying cargo or pulling a trailer.

With the exception of genuine dealer Parts and Accessories, dealer has no control over the design or application of accessories. In some cases, improper installation or use of accessories, or vehicle modifications, will void the vehicle warranty. In selecting and using accessories, and in loading the vehicle, you are personally responsible for your own safety and the safety of other persons involved.

Because an all-terrain vehicle is sensitive to increases in weight, changes in weight distribution, and aerodynamic forces, you must take extreme care in carrying cargo and/or in the fitting of accessories. The following general guidelines have been prepared to help you make your determinations.

- When adding cargo and pulling a trailer reduce speed. Shift transmission to “L” (Low) range. Braking distance is increased. Use extreme caution when climbing and descending hills, and traversing slopes. Adding cargo and pulling a trailer can make the vehicle difficult to steer and affect vehicle handling in an unpredictable manner.
- All cargo should be carried as low as possible to reduce the effect on the vehicle’s center of gravity. Cargo weight should also be equally distributed from side to side. Place cargo to the rear of a front carrier and to the front of a rear carrier. This helps maintain the stability of the vehicle by centralizing the weight. Do not allow cargo to extend beyond the edges of the carriers.
- Cargo should be securely attached. Make sure the cargo will not move around while you are riding. Recheck cargo security as often as possible (not while the vehicle is in motion) and adjust as necessary.
- Do not carry heavy or bulky items even on a cargo carrier. They are designed for light items,

and overloading can affect handling due to changes in weight distribution and aerodynamic forces.

- Do not install accessories or carry cargo that impairs the performance of the vehicle. Make sure that you have not adversely affected any lighting component, ground clearance, brake or control operation, wheel movement, or any other aspect of the vehicle's operation.
- Always subtract trailer tongue weight from the Maximum Weight capacity. Refer to the LOCATION OF THE WARNING AND SPECIFICATION LABELS chapter for details on the trailer hitch bracket.
- Weight attached to the handlebar will increase the mass of the steering assembly and can result in an unsafe riding condition.
- Windshields, trunk boxes, and other large items reduce the capability of adversely affecting stability and handling of the vehicle, because of their weight and the aerodynamic forces acting on these surfaces while the vehicle is in operation. Poorly designed or installed items can result in an unsafe riding condition.
- Never ride with passengers on the carriers. This ATV is not designed for carrying passengers on the carriers.

RIDING YOUR ATV

WARNING

Indicates a potential hazard that could result in serious injury or death.

Operator safety

- Wet brakes may have reduced stopping ability. Test your brakes after leaving water. If necessary, apply them lightly several times while driving slowly to allow friction to dry out the pads.
- Always check for obstacles or people behind the ATV before operating in reverse. When it's safe to proceed in reverse, move slowly and avoid turning at sharp angles.
- Always use the size and type of tires specified for your ATV, and always maintain proper tire pressure.
- Never modify an ATV through improper installation or use of accessories.
- Never exceed the stated load capacity for your ATV. Cargo must be properly distributed and securely attached. Reduce speed and follow the instructions in this manual for carrying cargo or towing. Allow a greater distance for braking.
- Always remove the ignition key when the vehicle is not in use to prevent unauthorized use or accidental starting.

- Children or pets shall not be carried on the racks.
- Never touch running parts, such as wheels, drive shaft, etc.

Know your ATV before riding

This ATV is intended for recreational use by experienced operators only. Even if you are an experienced operator of all other all-terrain ATVs or motorcycles, riding the ATV requires special skills acquired through practice. Take your time to fully learn techniques before attempting more difficult maneuvers.

For your safety, be sure you have read this Owner's Manual completely and understand the operation of the controls before you begin to ride. Read all caution

and warning labels on your ATV and pay particular attention to the safety information.

Ride with care and judgment

Get training if you are inexperienced.

Beginners should get training from a certified instructor. Start at slow speeds first to be familiar with this ATV even if you are an experienced rider. Do not operate at maximum performance until you are totally familiar with the ATV's handling and performance characteristics.

Take the time to learn the basic techniques well before attempting more difficult maneuvers.

WARNING

POTENTIAL HAZARD

Operating this ATV without proper instruction.

WHAT CAN HAPPEN

The risk of an accident is greatly increased if the operator does not know how to operate the ATV properly in different situations and on different types of terrain.

HOW TO AVOID THE HAZARD

Beginning and inexperienced operators should complete the certified training course offered by Dealers. They should then regularly practice the skills learned in the course and the operating techniques described in this Owner's Manual.

Never allow children under 16 years old to ride this ATV.



Apparel

Always wear clothing suited to the type of riding. ATV riding requires pencil protective clothing for comfort and to reduce the chance of injury:

WARNING

POTENTIAL HAZARD

Operating this ATV without wearing an approved motorcycle helmet, eye protection and protective clothing.

WHAT CAN HAPPEN

Operating without an approved motorcycle helmet increases your chances of a severe head injury or death in the event of an accident.

Operating without eye protection can result in an accident and increases your chances of a severe injury in the event of an accident.

Operating without protective clothing increases your chances of severe injury in the event of an accident.

HOW TO AVOID THE HAZARD

Always wear an approved motorcycle helmet that fits properly.

You should also wear:

- eye protection (goggles or face shield)
- gloves
- boots
- long-sleeved shirt or jacket
- long pants

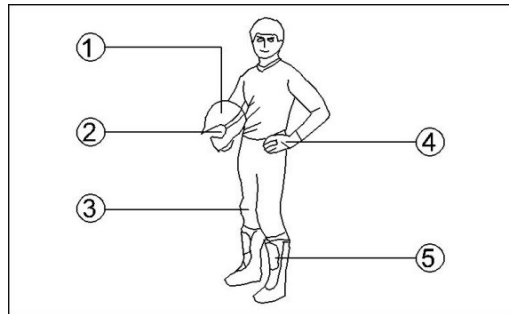

① Helmet

Your helmet is the most important piece of protective gear for safe riding. An approved helmet can prevent a severe head injury

② Eye protection

Do not depend on sunglasses for proper eye protection. A pair of goggles or a helmet face shield offers the best protection for your eyes. They should be kept clean and be a shatterproof design

③ Clothing

Always wear long sleeves and long pants to protect arms and legs. Riding pants with kneepads and a jersey with shoulder pads provide the best protection.

④ Gloves

Off-road style gloves with knuckle pads are

the best for comfort and protection.

⑤ Boots

The best footwear is a pair of strong over-the-calf boots with heels, like motto-cross boots.

Do not operate after consuming alcohol or drugs.

Operator's performance capability is reduced by the influence of alcohol or drugs.



WARNING

POTENTIAL HAZARD

Operating the ATV after consuming alcohol or drugs

WHAT CAN HAPPEN

Consumption of alcohol and/or drugs could seriously affect operator judgment. Reaction time may be slower and operator balance and perception could be affected. Consumption of alcohol and/or drugs before or while operating an ATV could result in an accident causing severe injury or death.

HOW TO AVOID THE HAZARD

Never consume alcohol or drugs before or while operating an ATV

Pre-operation checks

Always perform the pre-operation checks listed before riding for safety and proper care of your ATV.

WARNING

POTENTIAL HAZARD

Failure to inspect the ATV before operating.

Failure to properly maintain the ATV.

WHAT CAN HAPPEN

Increases the possibility of an accident or equipment damage.

HOW TO AVOID THE HAZARD

Always inspect your ATV each time you use it to make sure the ATV is in safe operating condition.

Always follow the inspection and maintenance procedures and schedules described in the Owner's Manual.

WARNING

POTENTIAL HAZARD

Operating this ATV at speeds too fast for your skills or the conditions.

WHAT CAN HAPPEN

Increases your chances of losing control of the ATV, which can result in an accident.

HOW TO AVOID THE HAZARD

Always go at a speed that is proper for the terrain, visibility and operating conditions, and your experience.

Do not operate at speeds too fast for your skills or the conditions.

Loading and accessories

Use extra caution when riding the ATV with additional loads, such as accessories or cargo. The ATV handling may be adversely affected. Reduce your speed when adding additional loads.

Weight of operator and baggage or cargo must not exceed:

Xwolf 700/Xwolf 700L/Xwolf 550/ Xwolf 550L:	230 kg (507lb).
Mud edition :	195 kg(430 lb).
Front carrier(Xwolf 700/Xwolf 550):	35.0 kg (77 lb)
Rear carrier: (Xwolf 700/Xwolf 550)	45.0 kg (100 lb)
Front carrier(Xwolf 700L/Xwolf 550L):	35.0 kg (77 lb)
Rear carrier: (Xwolf 700L/Xwolf 550L)	45.0 kg (100 lb)
Rear carrier(Mud edition):	45.0 kg (100 lb)
Trailer hitch:	
Pulling load (total weight of trailer and cargo):	3500 N
Tongue weight (vertical weight on trailer hitch point):	420N

WARNING

POTENTIAL HAZARD

Operating this ATV or carrying or towing cargo improperly.

WHAT CAN HAPPEN

Could cause changes in ATV handling which could lead to an accident.

HOW TO AVOID THE HAZARD

Never exceed the stated load capacity for this ATV.

Cargo should be properly distributed and securely attached.

Reduce speed when carrying cargo or pulling a trailer. Allow greater distance for braking.

Always follow the instructions in your Owner's Manual for carrying cargo or pulling a trailer.

During operation

Always keep your feet on the footboards during operation. Otherwise your feet may contact the wheel and could cause injury. Avoid wheelies and jumping. You may lose control of the ATV or overturn.

WARNING

POTENTIAL HAZARD

Attempting wheelies, jumps, and other stunts.

WHAT CAN HAPPEN

Increases the chance of an accident, including an overturn.

HOW TO AVOID THE HAZARD

Never attempt stunts, such as wheelies or jumps.

Don't try to show off.

Exhaust system

The exhaust system on the ATV is very hot during and following operation. Never touch the exhaust system. Park the ATV in a place where pedestrians or children are not likely to touch it.

WARNING

POTENTIAL HAZARD

Hot exhaust system.

WHAT CAN HAPPEN

Dry grass or brush or other combustible material accumulated around the engine area could catch fire.

Someone touching the exhaust system during or after operation could be burned.

HOW TO AVOID THE HAZARD

Do not operate, idle, or park the ATV in dry grass or other dry ground cover.

Keep the engine area free of dry grass, brush, or other combustible, material.

Do not touch the hot exhaust system.

Do not park the ATV in a place where others might be likely to touch it.

Be careful where you ride

- This ATV is designed for off-road use only. Riding on paved surfaces can cause loss of control. Do not ride on any public road, street, or highway. Riding on public roads can result in collisions with other vehicles.

WARNING

POTENTIAL HAZARD

Operating this ATV on public streets, roads or highways.

WHAT CAN HAPPEN

You can collide with another vehicle.

HOW TO AVOID THE HAZARD

Never operate this ATV on any public street, road or highway, even dirt or gravel one. In many states it is illegal to operate ATVs on public streets, roads and highways.

- Know the terrain where you ride. Ride cautiously in unfamiliar areas. Stay alert for roots, holes or rocks in the terrain, and other hidden hazards which may cause the ATV to upset.

WARNING

POTENTIAL HAZARD

Failure to use extra care when operating this ATV on unfamiliar terrain.

WHAT CAN HAPPEN

You can come upon hidden rocks, bumps, or holes, without enough time to react. Could result in the ATV overturning or going out of control.

HOW TO AVOID THE HAZARD

Go slowly and be extra careful when operating on unfamiliar terrain. Always be alert to changing terrain conditions when operating the ATV.

WARNING

POTENTIAL HAZARD

Failure to use extra care when operating on excessively rough, slippery or loose terrain.

WHAT CAN HAPPEN

Could cause loss of traction or ATV control, which could result in an accident, including an overturn.

HOW TO AVOID THE HAZARD

Do not operate on excessively rough, slippery or loose terrain until you have learned and practiced the skills necessary to control the ATV on such terrain. Always be especially cautious on these kinds of terrain.

- When riding in an area where you might not easily be seen, such as desert terrain, mount a caution flag on the ATV.

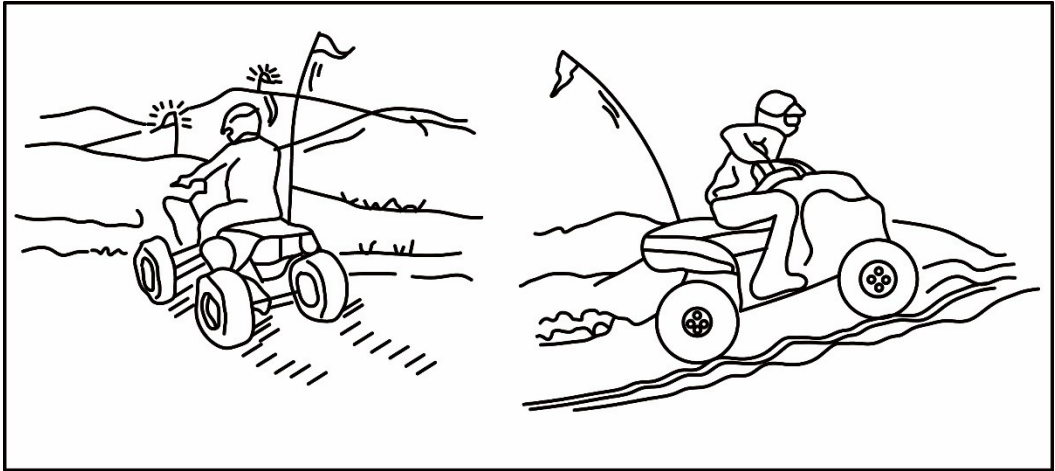

- Do not ride on private property without getting permission.

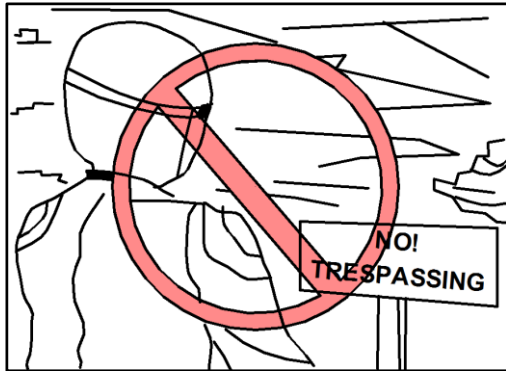

- Select a large, flat area off-road to become familiar with your ATV. Make sure that this area is free of obstacles and other riders. You should practice control of the throttle, brakes, shifting

procedures, and turning techniques in this area before trying more difficult terrain. Always avoid riding on paved surfaces: the ATV is designed for off-road use only, and handling maneuvers are more difficult to perform on pavement.

- Set the parking brake and start the engine. Once it has warmed up you are ready to begin riding your ATV. Remember that the engine and exhaust pipe will be hot when riding and afterwards; do not allow skin or clothing to come in contact with these components.

Turning you ATV

To achieve maximum traction while riding off-road in 2WD or 4WD, the two rear wheels turn together at the same speed. Furthermore, when riding in 4WD-LOCK ("DIFF. LOCK"), the front wheels also turn together at the same speed. Therefore, unless the wheel on the inside of the turn is allowed to slip or lose some traction, the ATV will resist turning. A special turning technique must be used to allow the ATV to make turns quickly and easily. It is essential that this skill be learned first at low speed.

WARNING

POTENTIAL HAZARD

Turning improperly.

WHAT CAN HAPPEN

The ATV could go out of control, causing a collision or overturn.

HOW TO AVOID THE HAZARD

Always follow proper procedures for turning as described in this Owner's Manual. Practice turning at low speeds before attempting to turn at faster speeds. Do not turn at speeds too fast for your skills or the conditions. Operate at a slow speed and allow extra time and distance for maneuvers when in 4WD-LOCK ("DIFF. LOCK").

As you approach a curve, slow down and begin to turn the handlebars in the desired direction. As you do so, put your weight on the footboard to the outside of the turn (opposite your desired direction) and lean your upper body into the turn. Use the throttle to maintain an even speed through the turn. This maneuver will let the wheel on the inside of the turn slip slightly, allowing the ATV to make the turn properly.

This procedure should be practiced at slow speed many times in a large off-road area with no obstacles. If an incorrect technique is used, your ATV may continue to go straight. If the ATV doesn't turn, come to a stop and then practice the procedure again. If the riding surface is slippery or loose, it may help to position more of your weight over the front wheels by moving forward on the seat.

Once you have learned this technique, you should be able to perform it at higher speeds or in tighter curves.

Improper riding procedures such as abrupt throttle changes, excessive braking, incorrect body movements, or too much speed for the sharpness of the turn may cause the ATV to tip. If the ATV begins to tip over to the outside while negotiating a turn, lean more to the inside. It may also be necessary to gradually let off on the throttle and steer to the outside of the turn to avoid tipping over.

Remember: Avoid higher speeds until you are thoroughly familiar with the operation of your ATV.

Climbing uphill

Use proper riding skill to avoid vehicle overturns on hills. Be sure that you can maneuver your ATV well on flat ground before attempting any incline and then practice riding first on gentle slopes. Try more difficult climbs only after you have learned more skills. In all cases avoid inclines with slippery or loose surfaces, or obstacles that might cause you to lose control. It is important

WARNING

POTENTIAL HAZARD

Operating on excessively steep hills.

WHAT CAN HAPPEN

The ATV can overrun more easily on extremely steep hills than on level surfaces or small hills.

HOW TO AVOID THE HAZARD

Never operate the ATV on hills too steep for the ATV or for your abilities. Practice on smaller hills before attempting large hills.

When you climbing a hill to make sure that your weight is transferred forward on the ATV. This can be accomplished by leaning forward and, on steeper inclines, standing on the footboards and leaning forward over the handlebars.

WARNING

POTENTIAL HAZARD

Climbing hills improperly.

WHAT CAN HAPPEN

Could cause loss of control or cause the ATV to overturn.

HOW TO AVOID THE HAZARD

Always follow proper procedures for climbing hills as described in this Owner's Manual.

Always check the terrain carefully before you start up any hill.

Never climb hills with excessively slippery or loose surfaces.

Shift your weight forward.

Never open the throttle suddenly. The ATV could flip over backwards.

Never go over the top of any hill at high speed. An obstacle, a sharp drop, or another vehicle or person could be on the other side of the hill.

If you are climbing a hill and you find that you have not properly judged your ability to make

it to the top, you should turn the ATV around while you still have forward motion (provided you have the room to do so) and descend the hill.

If your ATV has stalled or stopped and you believe you can continue up the hill, restart carefully to make sure you do not lift the front wheels which could cause you to lose control. If you are unable to continue up the hill, dismount the ATV on the uphill side. Physically turn the ATV around and then go downhill. If you start to roll backwards,

DO NOT use the rear brake to stop or try to put the ATV in gear. The ATV could easily tip over backwards. Instead, dismount the ATV immediately on the uphill side.

WARNING

POTENTIAL HAZARD

Improperly crossing hills or turning on hills.

WHAT CAN HAPPEN

Could cause loss of control or cause the ATV to overturn.

HOW TO AVOID THE HAZARD

Never attempt to turn the ATV around on any hill until you have mastered the turning technique as described in the Owner's Manual on level ground.

Be very careful when turning on any hill.

Avoid crossing the side of a steep hill if possible.

When crossing the side of a hill:

Always follow proper procedures as described in the Owner's Manual.

Avoid hills with excessively slippery or loose surfaces.

Shift your weight to the uphill side of the ATV.

WARNING

POTENTIAL HAZARD

Stalling rolling backwards or improperly dismounting while climbing a hill.

WHAT CAN HAPPEN

Could result in the ATV overturning.

HOW TO AVOID THE HAZARD

Use the proper gear and maintain a steady speed when climbing a hill.

If you lose all forward speed:

Keep weight uphill.

Apply the brakes.

Lock the parking brake after you are stopped.

If you begin rolling backwards:

Keep weight uphill.

Never apply the rear brake while rolling backwards.

Apply the front brake.

When fully stopped, apply the rear brake as well, and then lock the parking brake.

Dismount on uphill side or to a side if pointed straight uphill. Turn the ATV around and remount, following the procedure described in the Owner's Manual

Riding downhill

Use caution while descending a hill with loose or slippery surfaces. Braking ability and traction may be adversely affected by these surfaces. Improper braking may also cause a loss of traction.

When this ATV is in 4WD or 4WD-LOCK, all wheels (front and rear) are interconnected by the drive train. This means that applying either the front brake or the rear brake will brake all wheels. When descending hills, using either brake lever or the brake pedal will brake the wheels on the downhill side. Avoid sudden application of either the front or rear brake because the wheels on the uphill side could come off the ground. Apply both the front and rear brakes gradually

WARNING

POTENTIAL HAZARD

Going down a hill improperly.

WHAT CAN HAPPEN

Could cause loss of control or cause the ATV to overturn.

HOW TO AVOID THE HAZARD

Always follow proper procedures for going down hills as described in this Owner's Manual.

Note: a special technique is required when braking as you go down a hill.

Always check the terrain carefully before you starting down any hill.

Shift your weight backward.

Never go down a hill at high speed.

Avoid going down a hill at an angle that would cause the ATV to lean sharply to one side. Go straight down the hill where possible.

Crossing a slope

Crossing a sloping surface on your ATV requires you to properly position your weight to keep proper balance. Make sure that you have learned the basic riding skills on flat ground before attempting to traverse a sloping surface. Avoid slopes with slippery surfaces or rough terrain that may disturb your balance.

As you travel across a slope, lean your body in the uphill direction. It may be necessary to correct the steering when riding on loose surfaces by pointing the front wheels slightly uphill. When riding on slopes are sure not to make sharp turns either up or down hill.

If your ATV does begin to tip over, gradually steer in the downhill direction if there are no obstacles in your path. As you regain proper balance, gradually steer again in the direction you wish to travel.

WARNING

POTENTIAL HAZARD

Improperly crossing hills or turning on hills

WHAT CAN HAPPEN

Could cause loss of control or cause the ATV to overturn.

HOW TO AVOID THE HAZARD

Never attempt to turn the ATV around on any hill until you have mastered the turning technique as described in the Owner's Manual. On level ground.

Be very careful when turning on any hill. Avoid crossing the side of a steep hill if possible.

When crossing the side of a hill:

Always follow proper procedures as described in the Owner's Manual.

Avoid hills with excessively slippery or loose surfaces.

Shift your weight to the uphill side of the ATV.

Crossing through shallow water

The ATV can be used to cross slow moving, shallow water of up to a maximum of 35cm (14 inches) in depth. Before entering the water, choose your path cautiously. Enter where there is no sharp drop off, and avoid rocks or other obstacles which may be slippery or upset the ATV. Ride slowly and carefully

Test your brakes after leaving the water. Do not continue to ride your ATV without verifying that you have regained proper braking ability.

CAUTION

After riding your ATV in water, be sure to drain the trapped water by removing the check hoses at the bottom of the air filter case. Also, remove the drain plugs from the front and rear storage compartments and the V-belt case to drain any water that may have accumulated. Wash the ATV in fresh water if it has been operated in salt water or muddy conditions.



WARNING

POTENTIAL HAZARD

Operating this ATV through deep or fast flowing water.

WHAT CAN HAPPEN

Tires may float, causing loss of traction and loss of control, which could lead to an accident.

HOW TO AVOID THE HAZARD

Never operate this ATV in fast flowing water or in water deeper than that specified in you. Owner's Manual

Remember that wet brakes may have reduced stopping ability. Test your brakes after leaving water. If necessary, apply those several times to let friction dry out the linings.

Riding over rough terrain

Riding over rough terrain should be done with caution. Look out for obstacles which could cause damage to the ATV or could lead to an upset or accident. Be sure to keep your feet firmly fixed on the footboards at all times. Avoid jumping the ATV as loss of control and damage to the ATV may result.



WARNING

POTENTIAL HAZARD

Improperly operating over obstacles.

WHAT CAN HAPPEN

Could cause loss of control or a collision. Could cause the ATV to overturn.

HOW TO AVOID THE HAZARD

Before operating in a new area, check for obstacles.

Never attempt to ride over large obstacles, such as large rocks or fallen trees. When you go over obstacles, always follow proper procedures as described in the Owner's Manual.

Sliding and skidding

Care should be used when riding on loose or slippery surfaces since the ATV may slide. If unexpected and uncorrected, sliding could cause an accident.

To reduce the possibility for the front wheels to slide in loose or slippery conditions, putting your weight over the front wheels will sometimes help.

If the rear wheels of your ATV start to slide sideways, control can usually be regained (if there is place to do so) by steering in the direction of the slide. Applying the brakes or accelerating is not recommended until you have corrected the slide.

With practice, over a period of time, skill at controlled sliding can be improved. The terrain should be chosen carefully before attempting such maneuvers, since both stability and control are reduced. Bear in mind that sliding maneuvers should always be avoided on extremely slippery surfaces such as ice, since all control may be lost.



WARNING

POTENTIAL HAZARD

Skidding or sliding improperly.

WHAT CAN HAPPEN

You may lose control of this ATV. You may also regain traction unexpectedly, which may cause the ATV to overturn.

HOW TO AVOID THE HAZARD

Learn to safely control skidding or sliding by practicing at low speeds and on level, smooth terrain.

On extremely slippery surfaces, such as ice, go slowly and be very cautious in order to reduce the chance of skidding or sliding out of control.

What to do if

This section is designed to be a reference guide only. Make sure to read each section on riding techniques completely.

What to do

- If your ATV doesn't turn when you want it to: Bring the ATV to a stop and practice the turning maneuvers again. Be sure you are positioning your weight on the footboard to the outside of the turn. Put your weight over the front wheels for better control.
- If your ATV begins to tip while turning: Lean more into the turn to regain balance. If necessary, gradually release

the throttle and/or steer to the outside of the turn.

- If your ATV can't make it up a hill you are trying to climb: Turn the ATV around if you still have forward. If not, stop, dismount on the uphill side of the ATV and physically turn the ATV around. If the ATV starts to slip backwards DO NOT USE THE REAR BRAKE-the ATV may tip over on top of you. Dismount the ATV on the uphill side.
- If your ATV is crossing a sloping surface: Be sure to ride with your weight positioned towards the uphill side of the ATV to keep proper balance. If the ATV starts to tip, steer down the hill (if there are no obstacles in your way) to get

balance again. If you discover that the ATV is going to tip over, dismount on the uphill side.

- If your ATV meets shallow water: Ride slowly and carefully through slow moving water, watching for obstacles. Be sure to let water drain from the ATV and **CHECK YOUR BRAKES FOR PROPER OPERATION** when you come out of the water. Do not continue to ride your ATV until you have regained adequate braking ability.

- If your ATV starts to slide sideways:
- Steer in the direction of the slide if you have the place. Applying the brakes or accelerating is not recommended until you have corrected the slide.



WARNING

Indicates a potential hazard that could result in serious injury or death.

PERIODIC MAINTENANCE AND ADJUSTMENT

Periodic check, adjustment and lubrication will keep your machine in the securest and most efficient condition possible. Security is an obligation of the machine owner. The most important points of machine inspection, adjustment and lubrication are explained on the following pages.

Owner's manual and tool kit

You are advised to put this owner's manual and low-pressure tire gauge in the vinyl bag and always carry them along with the owner's tool kit.

The service information included in this manual is designed to provide you, the owner, with the essential information for completing your own preventive maintenance and minor repairs. The tools provided in the Owner's tool kit are enough for this purpose, except that a torque wrench is also necessary to correctly tighten nuts and bolts.

Periodic maintenance chart for the emission control system

NOTE: _____

- For ATVs not equipped with an odometer or an hour meter, follow the month maintenance intervals.
 - For ATVs equipped with an odometer or an hour meter, follow the km (mi) or hour's maintenance intervals. However, keep in mind that if the ATV isn't used for a long period of time, the month maintenance intervals should be followed.
 - Items marked with an asterisk should be performed by a dealer as they require special tools, data and technical skills.
-

NO.	ITEM	CHECK OR MAINTENANCE JOB		Initial			Every	
			km (mi)	1000 (600)	4000 (2500)	7000 (4400)	10000 (6300)	13000 (8200)
1	*	Fuel Line	• Check fuel hoses for cracks or other damage, and replace if necessary.			I	I	I
2		Spark Plug	• Check condition and clean, re-gap, or replace if necessary.	I	I	I	I	I
3	*	Valves	• Check valve clearance and adjust if necessary.	I		I	I	I
4	*	Crankcase breather system	• Check breather hose for cracks or other damage and replace if necessary.			I	I	I
5	*	Exhaust system	• Check for leakage and replace gasket(s) if necessary. • Check for looseness and tighten all screw clamps and joints if necessary.			I	I	I
6		Spark arrester	• Clean.			C	C	C

General maintenance and lubrication chart

NO.	ITEM	CHECK OR MAINTENANCE JOB		Initial	Every				
			km (mi)	1000 (600)	4000 (2500)	7000 (4400)	10000 (6300)	13000 (8200)	
1		Brake fluid	• Replace.	Every 2 years					
2	*	Front brake	• Check operation and correct if necessary. • Check fluid level and ATV for fluid leakage, and correct if necessary.						
			• Replace brake pads.	Whenever worn to the limit					
3	*	Rear brake	• Check operation and correct if necessary. • Check brake lever and pedal free play, and adjust if necessary.						
			• Replace brake pads.	Whenever worn to the limit					

NO.	ITEM	CHECK OR MAINTENANCE JOB		Initial			Every	
			km (mi)	1000 (600)	4000 (2500)	7000 (4400)	10000 (6300)	13000 (8200)
4	*	Brake hoses	• Check for cracks or other damage, and replace if necessary.	Every 4 years				
			• Replace.	Every 4 years				
5	*	Wheels	• Check run out and for damage, and replace if necessary.					
6	*	Tires	• Check tread depth and for damage, and replace if necessary. • Check air pressure and balance, and correct if necessary.					
7	*	Wheel hub bearings	• Check for looseness or damage, and replace if necessary.					
8	*	V-belt	• Check for wear, cracks or other damage, and replace if necessary.					
9	*	Chassis fasteners	• Make sure that all nuts, bolts, and screws are properly tightened.					

NO.	ITEM	CHECK OR MAINTENANCE JOB	Initial			Every		
			km (mi)	1000 (600)	4000 (2500)	7000 (4400)	10000 (6300)	13000 (8200)
10	*	Shock absorber assemblies		I	I	I	I	I
11		Stabilizer bushes				L	L	L
12	*	Rear knuckle pivots				L	L	L
13	*	Steering shaft				L	L	L
14	*	Steering system		I	I	I	I	I
15		Engine oil		R		R	R	R

NO.	ITEM	CHECK OR MAINTENANCE JOB		Initial			Every	
			km (mi)	1000 (600)	4000 (2500)	7000 (4400)	10000 (6300)	13000 (8200)
16	* Engine oil strainer	• Replace.		R		R	R	R
17	* Final gear oil	• Check ATV for oil leakage. Correct if necessary.		R		I	I	R
18	* Cooling system	• Check coolant level and ATV for coolant leakage, and correct if necessary.		I	I	I	I	I
		• Replace coolant		Every 2 years				
19	* Moving parts and cables	• Lubricate.			L	L	L	L
20	* Drive select lever safety system cable	• Check operation and adjust or replace if necessary.				I	I	I

NO.	ITEM	CHECK OR MAINTENANCE JOB	km (mi)	Initial			Every	
				1000 (600)	4000 (2500)	7000 (4400)	10000 (6300)	13000 (8200)
21	*	Throttle lever housing and cable		I	I/L	I/L	I/L	I/L
22	*	Front and rear brake switches		I	I	I	I	I
23	*	Lights and switches		I	I	I	I	I
24		Fuel filter						I

NO.	ITEM	CHECK OR MAINTENANCE JOB	Initial			Every		
			km (mi)	1000 (600)	4000 (2500)	7000 (4400)	10000 (6300)	13000 (8200)
25	*	Valve clearance	• Check and adjust if necessary					
26	*	CVT drive wheel ,driven wheel	• Clean • Check hoof, match roller ,replace worn					
27		Exhaust system	• Air tightness check					

NOTE:

- I: Inspection C:Clean R:Replace A:Adjust L:Lubricate
 - Some maintenance need more frequent service in wet, sandy, muddy, or dusty areas.
 - Hydraulic brake service:
 - Regularly check and, if necessary, correct the brake fluid level.
 - Every two years replace the internal components of the brake master cylinder and Calipers, and change the brake fluid.
 - Replace the brake hoses every four years and if cracked or damaged.
-

Engine Oil

In order for the engine and transmission to function properly, maintain the engine oil at the proper level, and change the oil and replace the oil filter in accordance with the Periodic Maintenance Chart. Not only do dirt and metal particles collect in the oil, but the oil itself loses its lubricated quality if used too long.



WARNING

HAZARD

Engine or transmission seizure.

WHAT CAN HAPPEN

Can lock the rear wheels causing an accident and injury.

HOW TO AVOID THE HAZARD

Do not operate this vehicle with insufficient, deteriorated, or contaminated engine oil.

Oil Level Inspection

The engine oil level should be checked before each ride. In addition, the oil must be changed and the oil filter cartridge replaced at the intervals specified in the periodic maintenance and lubrication chart.

1. Place the ATV on a level surface.
2. Check the engine oil level on a cold engine.

NOTE:

If the oil has just been changed, start the engine and run it for several minutes at idle speed. This fills the oil filter with oil. Stop the engine, and then wait several minutes until the oil settles.

3. Remove the engine oil filler cap, and then wipe the dipstick off with a clean rag.
4. Insert the dipstick into the filler hole (without screwing it in), and then remove it again to check the oil level.

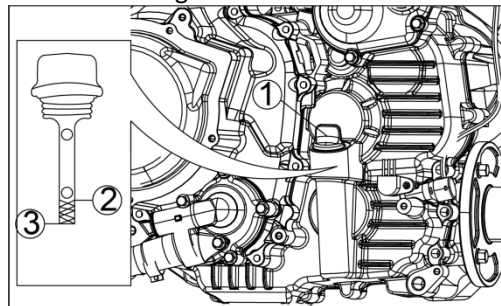

- ① Oil Filler Cap ② Upper Level Line
③ Lower Level Line

NOTICE

Racing the engine before the oil reaches every part can cause engine seizure.

Operation with insufficient, deteriorated, or contaminated engine oil will cause accelerated engine wear.

NOTE: _____

If the oil level is too high, remove the excess oil through the oil filler opening using a syringe or some other suitable device.

NOTE

If the engine is run without oil, it will be severely damaged.

Oil and/or Oil Filter Change (XWOLF700、XWOLF700L)

1. Place the ATV on a level surface.
2. Start the engine, warm it up for several minutes, and then turn it off.
3. Place an oil pan under the engine to collect the used oil.
4. Remove the engine oil filler cap, and then remove the engine oil drain bolt to drain the oil from the crankcase.

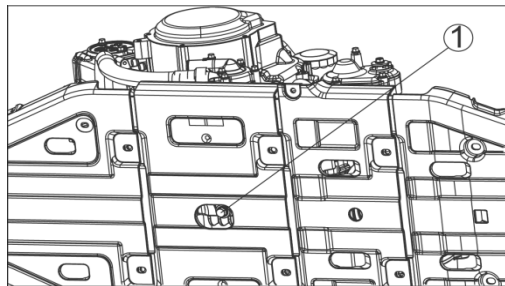

① Engine oil drain bolt.

5. Remove panels

6. Remove the oil filter cartridge with an oil filter wrench.

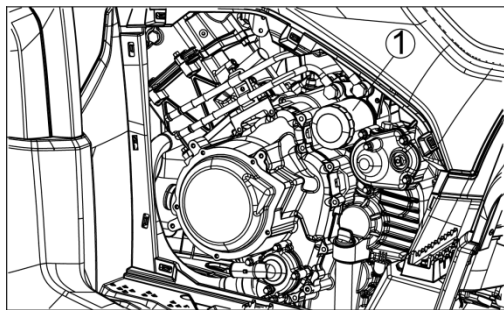

① Oil filter cartridge (XWOLF700 、 XWOLF700L)

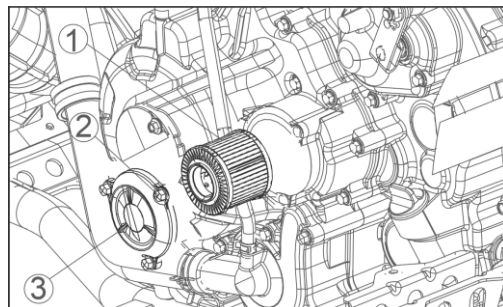

① Oil filter cartridge ② Cap ③ Bolt
(XWOLF550、 XWOLF550L)

7. Apply a thin coat of engine oil to the O-ring of the new oil filter cartridge.

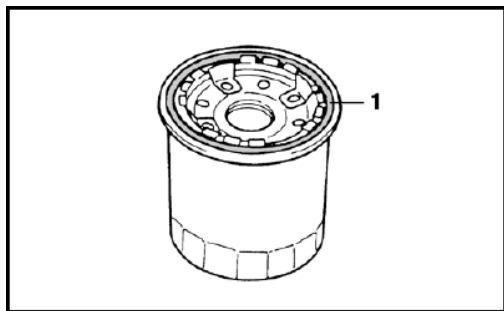

① O-ring (XWOLF700、XWOLF700L)

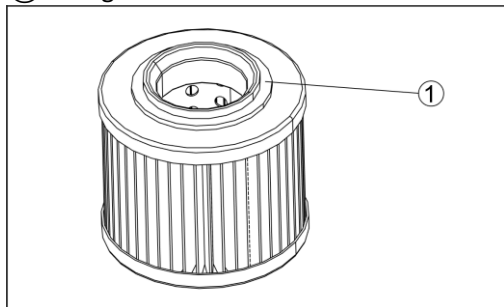

① O-ring (XWOLF550、XWOLF550L)

8. Install panels.

9. Install the engine oil drain bolt, and then tighten it to the specified torque.

Engine oil drain bolt	20 N.m(2.0kgf.m,15ft.lb)
-----------------------	--------------------------

10. Add the specified amount of the recommended engine oil, and then install and tighten the engine oil filler cap.

11. Start the engine, and then let it idle for several minutes while checking it for oil leakage. If oil is leaking, immediately term the engine off and check for the cause.

12. Turn the engine off, wait at least ten minutes, and then check the oil level and correct it if necessary.

13. Install panel



WARNING

HAZARD

Improper disposal of used motor oil.

WHAT CAN HAPPEN

Used motor oil is a toxic substance, which can pollute the environment.

HOW TO AVOID THE HAZARD

Contact your local authorities for approved disposal methods and follow those methods at all times.

Engine oil

Viscosity: SAE 10W-40

Capacity: 2.3L (XWOLF700)

Capacity: 2.5L (XWOLF500)

(when engine is completely dry)

NOTE

Do not add any chemical additive to the oil. Oils fulfilling the above requirements are fully formulated and provide adequate lubrication for the engine.

Although 10W-40 engine oil is the recommended oil for most conditions, the oil viscosity may need to be changed to accommodate atmospheric conditions in your riding area.

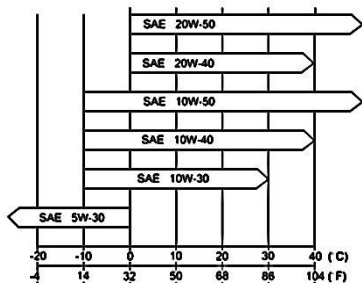

Final gear oil

The final gear case must be checked for oil leakage before each ride. If any leakage is found, have a dealer check and repair the ATV. In addition, the final gear oil level must be checked and the oil changed as follows at the intervals specified in the periodic maintenance and lubrications chart.

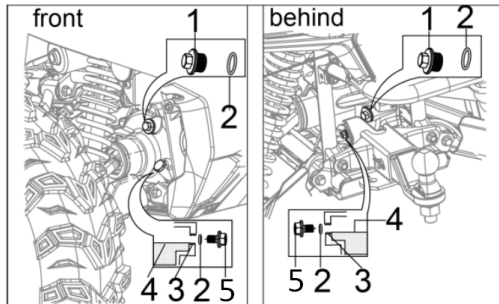

- ① Gear oiling bolt.
- ② Gasket

- ③ Correct oil level
- ④ Final gear oil
- ⑤ Gear oil level observation bolt

To check the final gear oil level

1. Place the ATV on a level surface.

NOTE: _____

The final gear oil level must be checked on a cold engine.

2. Remove the final gear oil filler bolt, and then check the oil level in the final gear case.

NOTE: _____

Make sure the oil level reaches the oil level check. hole.

3. If the oil is below the brim of the filler

hole, add sufficient oil of the recommended type to raise it to the correct level.

4. Install the oil filler bolt, and then tighten it to the specified torque.

NOTICE

Be careful not to allow any dirt or foreign materials to enter the transmission cases.

Tightening Torque

Oil Level Inspection Bolt	20 N-m (2.0 kg f-m, 15 ft.lb)
------------------------------	-------------------------------

To change the final gear oil

1. Place the ATV on a level surface.
2. Place an oil pan under the final gear case to collect the used oil.
3. Remove the final gear oil filler bolt and the final gear oil drain bolt to drain the

oil from the final gear case.

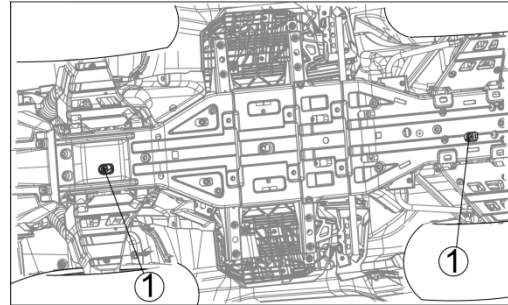

- ① Final gear oil drain bolt

4. Install the drain bolt, and then tighten it to the specified torque.

 **WARNING**

HAZARD

Improper disposal of used transmission case oil.

WHAT CAN HAPPEN

Used transmission case oil is a toxic substance, which can pollute the environment.

HOW TO AVOID THE HAZARD

Contact your local authorities for approved disposal methods and follow those methods at all times.

Tightening Torque

Transmission	20 N-m (2.0 kg f-m, 15 ft.lb)
Case Drain Plug	

 **WARNING**

HAZARD

Getting transmission case oil on tires.

WHAT CAN HAPPEN

Can make them slippery which can cause an accident and injury.

HOW TO AVOID THE HAZARD

Clean up any spilled oil immediately using soap and water.

Transmission Case Oil

Oil Capacity	0.3 L (0.3US qt)
Oil Viscosity	SAE80W-90

NOTE

Do not add any chemical additive to the oil. Oils fulfilling the above requirements are fully formulated and provide adequate lubrication for the transmission.

Cooling System

Radiator and Cooling Fan:

Check and clean the screen and radiator fins for obstruction by insects or mud in accordance with the Periodic Maintenance Chart. In dusty areas, the radiator should be cleaned more frequently than the recommended interval.

WARNING

HAZARD

The cooling fan turns on automatically, even with the ignition switch off.

WHAT CAN HAPPEN

Can cause injury to your hands if you touch the turning fan.

HOW TO AVOID THE HAZARD

Keep your hands and clothing away from the fan blades at all times.

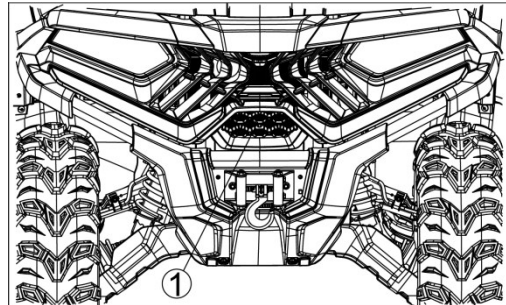

Radiator Screen

1. Clean the grille, screen, and radiator fins of any obstructions with a stream of low-pressure water.

2. If insects or mud cannot be completely removed, it should be cleaned by an authorized dealer.

NOTICE

Using high-pressure water, as from a car wash facility, could damage the radiator fins and impair the radiator's effectiveness.

Do not obstruct or deflect airflow through the radiator by installing unauthorized accessories in front of the radiator or behind the cooling fan. Interference with the radiator airflow can lead to overheating and consequent engine damage.

Coolant:

Coolant absorbs heat from the engine

and transfers it to the air at the radiator. If the coolant level becomes low, the engine overheats and may suffer damage. Check the coolant level each day before operating the vehicle, and replenish coolant if the level is low. Change the coolant in accordance with the Periodic Maintenance Chart.

Coolant Level Inspection

1. Situate the vehicle on level ground.
2. Check the coolant level through the coolant level gauge on the reserve tank. The coolant level should be between the "MAX" and "MIN" marks.

NOTE

Check the level when the engine is cold (room or atmospheric temperature).

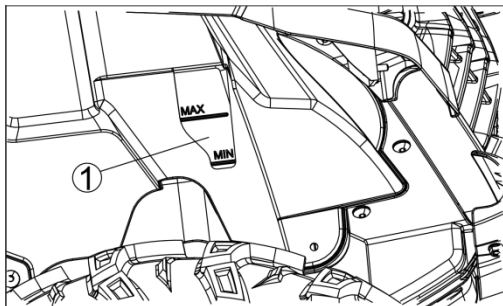

① Reserve Tank

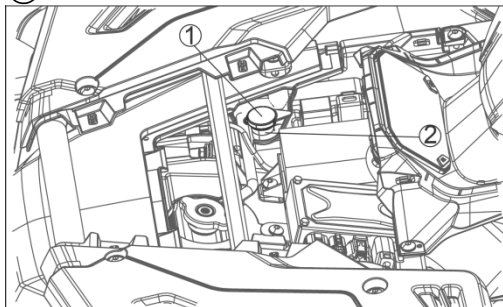

① Cap ② Reserve Tank.

3. If the amount of coolant is insufficient, remove the cap from the reserve tank and add coolant through the filler opening to the "MAX" mark. Install the cap.

Recommended Coolant Solution

Soft Water 50%: Coolant 50% (5 : 5)

Recommended Coolant:

Permanent type coolant (ethylene glycol plus corrosion and rust inhibitor chemicals for aluminum engines and radiator).

NOTE

In an emergency you can add water alone to the coolant reserve tank, however it must be returned to the correct mixture ratio by the addition of antifreeze concentrate as soon as possible.

A permanent type of antifreeze is installed in the cooling system when shipped. It is colored green and contains ethylene glycol. It is mixed at 30% and has the freezing point of -15°C (5°F).

NOTICE

If coolant must be added often, or the reserve tank completely runs dry, there is probably leakage in the system. Have the cooling system inspected by your authorized dealer.

Checking plug

The standard spark plug is shown in the table. The spark plugs should be taken out in accordance with the Periodic Maintenance Chart for cleaning, inspection, and resetting of the plug gap.

Maintenance

If the plugs are oily or have carbon build up on them, clean them. The plugs may also be cleaned using a high flash-point solvent and a nonmetal brush (nylon etc.). Measure the gap with a wire-type thickness gauge, and adjust the gap if incorrect by bending the outer electrode. If the spark plug electrodes are corroded or damaged, or if the insulator is cracked, replace the plugs.

Use the standard plug. To remove the spark plug

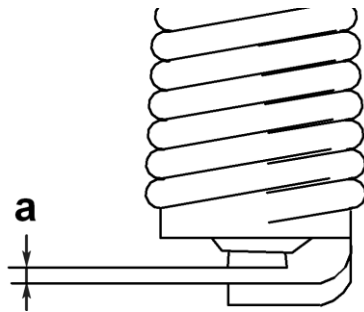

a). Spark plug gap

1. Remove the spark plug cap.
2. Remove the spark plug with the spark plug wrench.

To check the spark plug

1. Check that the porcelain insulator around the center electrode of the spark plug is a medium-to-light tan (the ideal color when the ATV is ridden normally).



WARNING

HAZARD

Hot exhaust pipe.

WHAT CAN HAPPEN

Can burn your hands.

HOW TO AVOID THE HAZARD

Check the exhaust pipe first and, if hot, wait until it gets cold.

NOTE

If the spark plug shows a distinctly different color, the engine could be operating improperly. Do not attempt to diagnose such problems yourself. Instead, have a dealer check the ATV.

2. Check the spark plug for electrode erosion and excessive carbon or other deposits, and replace it if necessary.

To install the spark plug

1. Measure the spark plug gap with a wire thickness gauge and, if necessary, adjust the gap to specification.

Spark plug gap:

0.8~1.0 mm (0.031~0.039 in)

2. Clean the surface of the spark plug gasket and its mating surface, and then wipe off any grime from the spark plug threads.
3. Install the spark plug with the spark plug wrench, and then tighten it to the specified torque.

Tightening torque:

Park plug:

12.5 Nm (1.25 m·kgf, 9.1 ft·lbf)

4. Install the spark plug cap.

Air filter cleaning

A clogged air cleaner restricts the engine's air intake, increases fuel consumption, reduces engine power, and causes spark plug fouling.

WARNING

HAZARD

A clogged air cleaner.

WHAT CAN HAPPEN

May allow dirt and dust to enter the carburetor and stick the throttle open. This could cause an accident.

HOW TO AVOID THE HAZARD

Clean the air cleaner regularly and according to the instructions in this section.

NOTICE

A clogged air cleaner may allow dirt and dust to enter the engine causing excessive wear and possibly engine damage.

The air cleaner element must be cleaned in accordance with the Periodic Maintenance Chart. In dusty areas, the element should be cleaned more frequently than the recommended interval. After riding through rain or on muddy roads, the element should be cleaned immediately.

Element Cleaning

1. Remove the seat.
2. Rotation to the left and remove the air cleaner housing cover.

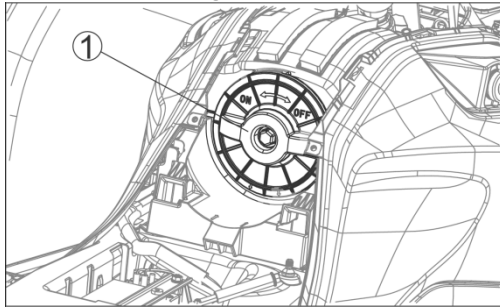

① Air Cleaner Housing Cover

3. Pull out the element and element frame from the air cleaner housing.

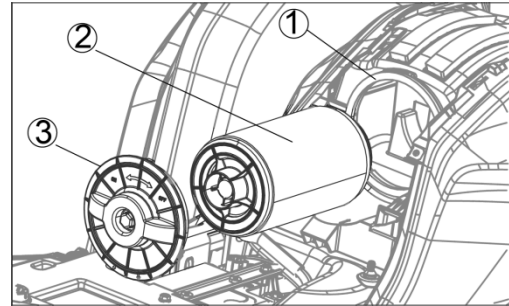

① Air Cleaner Housing

② Air Cleaner Element

③ Air Cleaner Housing Cover

NOTE:

Check inside the intake tract and carburetor for dirt. If dirt is present, clean the intake tract and carburetor thoroughly. You may also need to replace the air cleaner and seal the air cleaner housing and intake tract.

4. Push a clean, lint-free towel into the intake tract to keep dirt or other foreign material from entering.
5. Wipe out the inside of the air cleaner housing with a clean damp towel.

 **WARNING**

HAZARD

Dirt or dust allowed into the carburetor.

WHAT CAN HAPPEN

Can cause the throttle to stick open. This could cause an accident.

HOW TO AVOID THE HAZARD

Be sure to cover the air cleaner opening to the carburetor after removing the element. Clean the air cleaner housing as described in this section.

NOTICE

If dirt gets through into the engine, excessive engine wear and possibly engine damage will occur.

6. Clean the element in a bath of high flash-point solvent using a soft bristle brush.

 **WARNING**

HAZARD

Cleaning the air cleaner element with gasoline or low flash-point solvent.

WHAT CAN HAPPEN

Gasoline or low flash-point solvents are extremely flammable and can be explosive under certain conditions.

A fire or explosion can cause severe injury or death.

HOW TO AVOID THE HAZARD

Use a high flash-point solvent to clean the air cleaner element. Never use gasoline or low flash-point solvents.

Clean the element in a well-ventilated area free from any source of flame or sparks; this includes any appliance with a pilot light.

7. Squeeze it dry in a clean towel. Do not wring the element or blow it dry; the element can be damaged.

8. Check the element for visible damage. If it is torn, punctured, or hardened, replace it. After cleaning, saturate the element with a high -quality foam air cleaner oil, squeeze out the excess, then wrap it in a clean rag and squeeze it as dry as possible. Be careful not to tear the element.
9. Install the element on the inner metal net.
10. Install the air cleaner element to the element frame
11. Install the element in the air cleaner housing.
12. Clamp the air cleaner housing cover securely.
13. Install the seat.

Valve clearance adjustment

The proper valve clearance changes with use, leading to incorrect fuel/air supply or engine noise. To prevent this, the valve clearance must be adjusted periodically. This adjustment however, should be left to a professional service technician.

Spark Arrester

This vehicle is equipped with a spark arrester approved for off-road use by the U.S. Forest Service. It must be properly maintained to ensure its efficiency. In accordance with the Periodic Maintenance Chart, clean the spark arrester.



WARNING

HAZARD

Incorrectly installed spark arrester.

WHAT CAN HAPPEN

Can emit sparks which can cause a fire.

HOW TO AVOID THE HAZARD

Be sure the spark arrester/muffler and drain plug are installed securely.

1. Remove the bolt from the muffler.



WARNING

HAZARD

Hot muffler.

WHAT CAN HAPPEN

Can burn your hands.

HOW TO AVOID THE HAZARD

Wear gloves while cleaning the spark arrester. The engine must be running during this procedure.

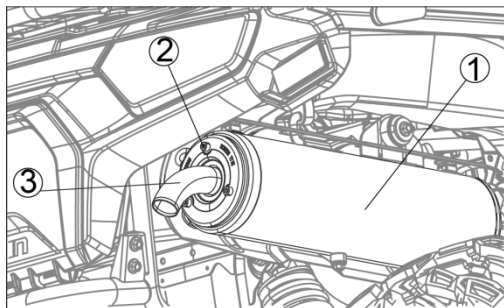

- ① Muffler
- ② Bolt
- ③ Spark Arrester

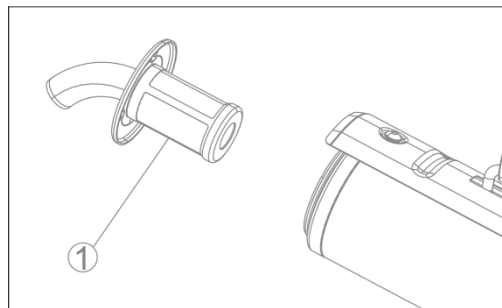

- ① Spark Arrester

2. In an open area away from combustible materials, start the engine with the transmission in neutral.



WARNING

HAZARD

Cleaning the spark arrester near combustible materials.

WHAT CAN HAPPEN

Can cause a fire resulting in burns.

HOW TO AVOID THE HAZARD

Never run the engine with the spark arrester disassembled near combustible materials. Hot carbon particles are emitted during the cleaning procedure.

3. Raise and lower engine speed while tapping on the muffler with a rubber mallet until carbon particles are purged from the muffler.



WARNING

HAZARD

Running the engine without ventilation.

WHAT CAN HAPPEN

Breathing exhaust gas leads to carbon monoxide poisoning, asphyxiation, and death. Exhaust gases contain carbon monoxide; a colorless, odorless, poisonous gas.

HOW TO AVOID THE HAZARD

Do not start or run the engine in a closed area such as a garage.

4. Stop the engine.
5. Install the spark arrester in place and tighten the spark arrester bolt to the specified torque.

Tightening Torque

Spark Arrester Bolt	11 N-m (1.1 kg f-m, 97 in.lb)
---------------------	-------------------------------

Shift Lever

NOTICE

Before shifting, you must stop the machine and return the throttle lever to its closed position until the engine speed to the specified idling speed. Otherwise, the transmission may be damaged.

1. Check operation of the lever before start the engine.
2. Make sure moving the shift lever into the "N" position of the shift guide.
3. Turn the ignition switch to "ON" and check the neutral indicator light goes on.

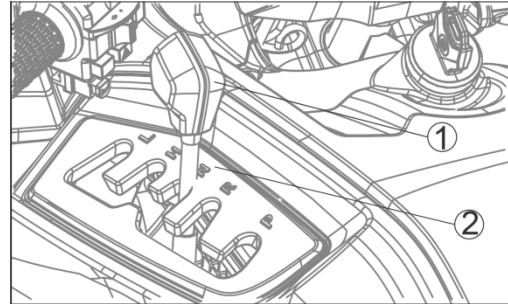

- ① Shift Lever
- ② "N" position

WARNING

HAZARD

Operating with improperly adjusted drive select lever.

HAZARDWHAT CAN HAPPEN

You may lose control of the gear shifting, which lead to accident.

HOW TO AVOID THE HAZARD

Make sure moving the shift lever into the "N" position and neutral indicator light goes on before start the engine.

Shift Lever Adjustment

1. Turn the ignition switch is to ON and make sure the engine stop switch in the OFF "" position.
2. Loosen the locknuts of rod. Shift the gear to neutral by moving the shift lever

and/or turn the rod. (The neutral indicator light goes on.)

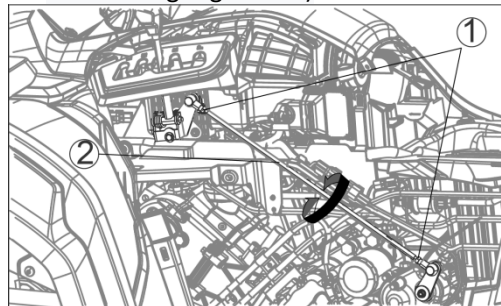

① Locknuts

② Rod

3. Provide standard tip/philips screwdriver (tool kit) and pass the standard tip/phillips screwdriver through the shift arm into the index hole at the transmission case cover.
4. Turn the rod clockwise or

counterclockwise until the drive select lever into the "N" position of the shift guide and tighten the locknuts.

5. After adjustment, start the engine and test ride the ATV to be sure the drive select lever is operating properly.

Belt Drive Transmission (CVT)

The vehicle is equipped with a belt-driven Continuously Variable Transmission (CVT). This automatic drive system, although simple to operate, does require periodic inspection since the drive belt wears with normal use

Inspection should be done by an authorized dealer.

Periodic Drive Belt Inspection Requirements Neglect, abuse, or failure to

maintain the transmission can result in belt damage and failure.

Inspection of the transmission drive belt is required at least every 2 000 km (1 200 mi.) or year of use whichever comes first, since drive belts wear with normal use. More frequent inspection is necessary if the vehicle is subjected to hard usage. If excessive belt slippage occurs, do not ride the vehicle until damaged components are repaired.



WARNING

HAZARD

Moving parts are exposed when the torque converter cover is removed.

WHAT CAN HAPPEN

Moving parts can cause severe bodily injuries and/or catch clothing and cause injury.

HOW TO AVOID THE HAZARD

Never operate the vehicle without the torque converter cover installed.

Causes of accelerated Belt Wear

Avoid these hard usage conditions to obtain maximum belt life and prevent accelerated belt wear and deterioration.

1. Operating the vehicle in high range while climbing hills, carrying heavy loads, or

pulling a trailer.

2. Exceeding maximum vehicle load or trailer weight.
3. Operating in mud or water deeper than recommended.
4. Operating in extremely dusty conditions.
5. Continued operation with excessive belt slippage.
6. Failure to apply the foot and hand brake controls while descending hills.
7. Indications of Excessive Belt Slippage

Excessive slippage will accelerate belt wear and lead to failure. Recognize these symptoms of excessive belt slippage. If excessive slippage occurs, do not continue to ride the vehicle until all damaged components are repaired.

1. Smell of burning rubber.
2. Visible white smoke.
3. Sluggish initial acceleration or loss of power.
4. Engine rpm is higher for the same vehicle speed.
5. Engine vibration.

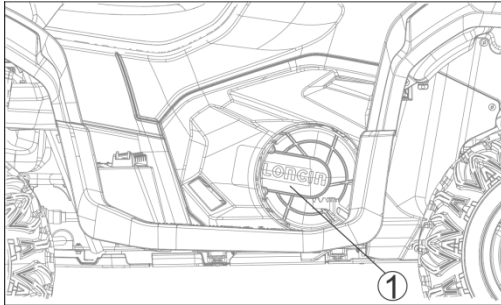

Belt Drive Transmission (CVT)

Brakes

Disc and brake pad wear is

automatically compensated for and has no effect on the brake levers and pedal action. There are no parts that require adjustment on the brake.

WARNING

HAZARD

Air in brake line.

WHAT CAN HAPPEN

Can make the brake feel mushy or soft. This may cause reduced braking performance or brake failure and result in an accident.

HOW TO AVOID THE HAZARD

If brake lever travel is excessive or the brake feels mushy, have an authorized dealer inspect it immediately.

Brake Wear Inspection

In accordance with the Periodic Maintenance Chart, inspect the brakes for wear. For each front disc brake caliper, if the thickness of either pad is less than 1 mm (0.04 in.), replace both pads in the caliper as a set. For the rear disc brake caliper, if the thickness of the pad is less than 1.5 mm (0.04 in.), replace the pad in the caliper. Pad wear inspection and pad replacement should be done by an authorized dealer.

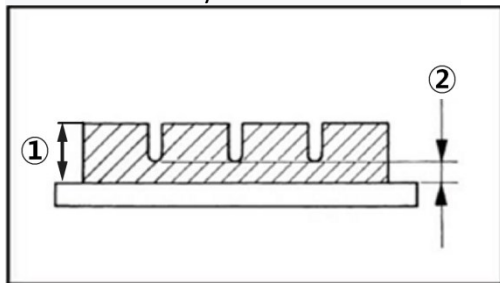

① Lining Thickness ② 1.5 mm (0.04 in.)

Disc Brake Fluid

In accordance with the Periodic Maintenance Chart, inspect the brake fluid level in the front and rear brake fluid reservoirs and change the brake fluid. The brake fluid should also be changed if it becomes contaminated with dirt or water.

Fluid Requirement

Use extra heavy-duty brake fluid only from a container marked DOT4.

NOTICE

Do not spill brake fluid onto any painted surface. It will damage the paint. If brake fluid is spilled, wash it off immediately with water.

 **WARNING**

HAZARD

Contaminated brake fluid.

WHAT CAN HAPPEN

Can reduce braking performance or cause brake failure, resulting in an accident.

HOW TO AVOID THE HAZARD

Do not use brake fluid from a container that has been left open or that has been unsealed for a long time. The fluid will absorb moisture and may be contaminated with dust and dirt.

 **WARNING**

HAZARD

Damaged or leaking brake hoses and fittings.

WHAT CAN HAPPEN

Can cause brake failure resulting in an accident.

HOW TO AVOID THE HAZARD

Inspect brake fluid level regularly.
Replace any damaged or leaking brake hoses and fittings.
Maintain the brake system in accordance with the Periodic Maintenance Chart.

Cable inspection and lubrication

The operation and the condition of all control cables should be checked before each ride, and the cables and cable ends should be lubricated if necessary. If a cable is damaged or does not move smoothly, have a dealer check or replace it.

NOTICE

Corrosion can result when the cable sheaths become damaged, and cables can also become frayed or kinked, which could restrict the operation of controls and lead to an accident or injury.

Inspect cables frequently. Replace damaged cables.

Wheel removal

1. Raise the wheel by placing a suitable stand under the frame.
2. Remove the nut from the wheel.
3. Remove the wheel assembly

Wheel installation

When installing the wheel, reverse the removal procedure.

Tighten the wheel bolts to the specified torques. Battery

Inspect the corrosion appearance of the electrodes by the electrolyte leaked.

Replenishing the battery

A poorly maintained battery will corrode and discharge quickly. The battery should be checked at least once a month.

1. When the machine is not to be used for a month or longer, Disconnect the negative (-) lead and the positive (+) lead, then remove the battery and put it in a cool, dark place. Thoroughly recharge the battery before reusing.
2. If the battery is to be stored for a longer period than the above, check the rated voltage at least once a month and recharge the battery when it is too low.
3. Always make sure the connections are right when putting the battery back in the machine. Make sure the breather

hose is properly connected and is not damaged or obstructed.

Fuse replacement

1. The fuse case is placed under the seat. The fuse is placed in the starting relay.
2. If the fuse is blown, turn off the main switch and equip a new fuse of the specified amperage. Then turn on the switches. If the fuse immediately blows again, consult your dealer. .

Troubleshooting charts

1. Fuel

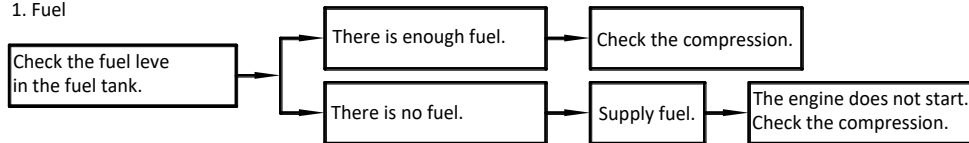

2. Compression

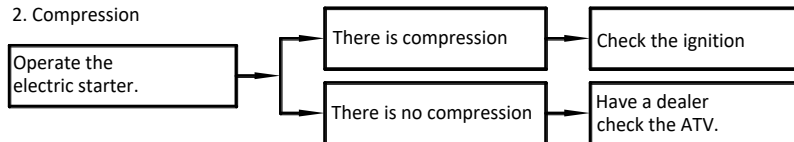

3. Ignition

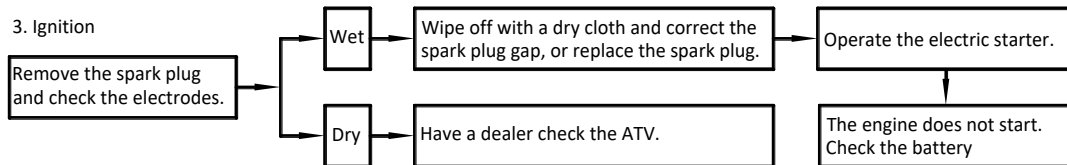

4. Battery

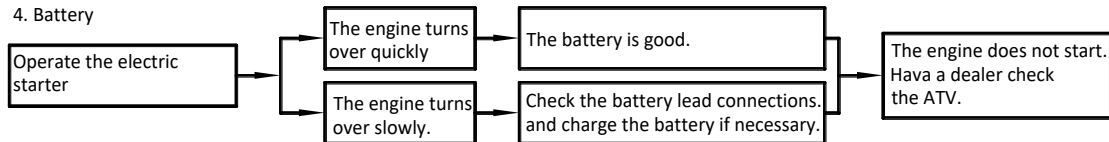

CLEANING AND STORAGE

Cleaning

Frequent, thorough cleaning of your machine will not only enhance its appearance but will improve its general performance and extend the useful life of many components.

1. Before cleaning the machine.
 - a. Block off the end of the exhaust pipe to prevent water entry. A plastic bag and strong rubber band may be used.
 - b. Assure the spark plug and all filler caps are correctly installed.
2. If the engine case is extremely greasy, apply degreaser with a paintbrush. Do not apply degreaser to the wheel axles.
3. Rinse the dirt and degreaser off with a garden hose. Use only sufficient pressure to do the job.
4. Once the majority of the dirt has been hosed off, wash all surfaces with warm water and mild, detergent-type soap. An old toothbrush or bottle brush is handy for hard-to-get-at places.
5. Rinse the machine off immediately with clean water and dry all surfaces with a chamois, clean towel or cloth.
6. Clean the seat with vinyl upholstery cleaner to keep the cover pliable and glossy.
7. Automotive type wax may be applied to all painted and chrome plated surfaces. Avoid

combination cleaner-waxes. Many contain abrasives which may mar the paint or protective finish. When finished, start the engine and let it idle for several minutes.

Spark Arrester Cleaning Process

1. Before starting the cleaning:

- a) Place the ATV in an open area and make sure there is no flammable material around;
- b) Do not dismantle the muffler before it cools down;
- c) Do not start the engine after you dismantle the rear part of the muffler;
- d) Do wear the eye-protector and make sure there is no person at the back of the ATV.
- e) Check whether the gasket is damaged. If it is damaged, replace it.

2. Cleaning process:

- a) Dismantle the rear pipe which connected to the muffler by bolt;
- b) Take the rear pipe from the muffler;
- c) Knock the pipe by a soft hammer gently and then brush the inner wall of the pipe to clean the carbon deposit;
- d) Assemble the rear pipe back to the muffler;
- e) Fasten it to the muffler by the bolts.

3. Maintenance period:

Do a cleaning of the pipe either every 2000km (1200miles) or every 6 months, whichever one arrives first.

Storage

Long term storage (60 days or more) of your machine will require some protective procedures to guard against deterioration. After completely cleaning the machine, prepare for storage as follows:

1. Fill the fuel tank with fresh fuel
2. Remove the spark plug, pour about one tablespoon of SAE 10W30 or 20W40 motor oil in the spark plug hole and reinstall the spark plug. Ground the spark plug wire and turn the engine over several times to coat the cylinder wall with oil.
3. Lubricate all control cables.
4. Block up the frame to raise all wheels off the ground.
5. Tie a plastic bag over the exhaust pipe outlet to prevent moisture from entering.
6. If storing in a damp or salty atmosphere, coat all exposed metal surfaces with a light film of oil.
Do not apply oil to any rubber parts or the seat cover.
7. Remove the battery and charge it. Store it in a dry place and recharge it once a month. Do not store the battery in an extremely warm or cold place (less than 0°C (30°F) or more than 30°C

(90°F).

Transporting the ATV

Follow these procedures when transporting the vehicle:

- Turn off the engine and remove the key to prevent loss during transporting.
- Ensure the fuel cap is installed correctly and secure.
- Ensure the seat is installed correctly and secure.
- Place the gear into any position except the parking position, and block the front and rear wheels to prevent the vehicle from moving.
- Secure both the front and rear of the vehicle frame to prevent the vehicle from sliding or moving during transport.

NOTICE
Never transport the ATV with the gear selector in Park position. Transmission damage will result

SPECIFICATION

Model	XWOLF 700	XWOLF 700L
Dimension:		
Overall length	2,040mm (80.3 in)	2,220 mm (87.4in)
Overall width	1,190mm (46.9 in)	1,190 mm (46.9 in)
Overall height(22in Tires)	1,298mm (51.1 in)	1,380 mm (54.3 in)
Seat height(22in Tires)	8,90mm (35.0 in)	8,90 mm (35.0 in)
Wheel base	1,300mm (51.2 in)	1,480 mm (58.3 in)
Min. ground clearance	280mm (11.0 in)	280 mm (11.0 in)
Minimum turning radius	3,450mm (135.8 in)	3,750 mm (147.6 in)
Maximum mass (es)	622kg(1371 lb)	640 kg (1410 lb)
Engine:		
Type	LX1102MU	LX1102MU
Cylinder arrangement	Single cylinder	Single cylinder
Displacement	686 cm ³	686 cm ³
Bore × Stroke	102×84 mm	102×84 mm
Compression ratio	9.7 : 1	9.7 : 1
Starting system	Electric starter	Electric starter
Lubrication systems:	Mixed lubrication	Mixed lubrication

Model	XWOLF 550	XWOLF 550L
Dimension:		
Overall length	2,040mm (80.3 in)	2,220 mm (87.4in)
Overall width	1,180mm (46.5in)	1,180 mm (46.5 in)
Overall height(22in Tires)	1,240mm (48.8 in)	1320 mm (52 in)
Seat height(22in Tires)	8,90mm (35.0 in)	8,90mm (35.0 in)
Wheel base	1,300mm (51.2 in)	1,480 mm (58.3 in)
Min. ground clearance	280mm (11.0 in)	280 mm (11.0 in)
Minimum turning radius	3600mm (141.7 in)	4160 mm (163.8 in)
Maximum mass (es)	622kg(1371 lb)	630 kg (1388 lb)
Engine:		
Type	LX191MR	LX191MR
Cylinder arrangement	Single cylinder	Single cylinder
Displacement	499.5 cm ³	499.5 cm ³
Bore × Stroke	91×76.8 mm	91×76.8 mm
Compression ratio	11.1 : 1	11.1 : 1
Starting system	Electric starter	Electric starter
Lubrication systems:	Mixed lubrication	Mixed lubrication

Model	Mud plate	Mud plate (Long pattern)
Dimension:		
Overall length	2125mm(83.7in)	2305mm(90.7in)
Overall width	1230mm(48.4in)	1230mm(48.4in)
Overall height(22in Tires)	1323mm(52.1in)	1405mm(55.3in)
Seat height(22in Tires)	915mm (36.0 in)	915mm (36.0 in)
Wheel base	1,300mm (51.2 in)	1,300mm (51.2 in)
Min. ground clearance	305mm (12.0 in)	305mm (12.0 in)
Minimum turning radius	3,450mm (135.8 in)	3,750 mm (147.6 in)
Maximum mass (es)	655 kg (1444 lb)	/
Engine:		
Type	LX1102MU	LX1102MU
Cylinder arrangement	Single cylinder	Single cylinder
Displacement	686 cm ³	686 cm ³
Bore × Stroke	102×84 mm	102×84 mm
Compression ratio	9.7 : 1	9.7 : 1
Starting system	Electric starter	Electric starter
Lubrication systems:	Mixed lubrication	Mixed lubrication

Model	XWOLF 700/XWOLF 700L	XWOLF 550/XWOLF 550L
Engine Oil Capacity for crankcase	2.3L	2.5L
Engine Oil Capacity for transmission	/	/
Fuel Capacity	21L	21L
Starting	Electric	Electric
Transmission	CVT	CVT
Front Suspension	Double wishbone	Double wishbone
Rear Suspension	Swing arm	Swing arm
Front/Rear Brakes	Disc brake	Disc brake
Parking Brake	Mechanical Lock	Mechanical Lock
Front Tires	25×8-12 or 26×9-12	25×8-12
Rear Tires	25×10 - 12 or 26×10-12	25×10 – 12
pressure	Tire pressure is shown on the tire	Tire pressure is shown on the tire
Max. Load Capacity	230kg	230kg
Battery(Green)	12V-32Ah	12V-20Ah

Model	Mud plate	Mud plate (Long pattern)
Engine Oil Capacity for crankcase	2.3L	2.5L
Engine Oil Capacity for transmission	/	/
Fuel Capacity	21L	21L
Starting	Electric	Electric
Transmission	CVT	CVT
Front Suspension	Double wishbone	Double wishbone
Rear Suspension	Swing arm	Swing arm
Front/Rear Brakes	Disc brake	Disc brake
Parking Brake	Mechanical Lock	Mechanical Lock
Front Tires	27×9-14	27×9-14
Rear Tires	27×11-14	27×11-14
pressure	Tire pressure is shown on the tire	Tire pressure is shown on the tire
Max. Load Capacity	220kg	195kg
Battery(Green)	12V-32Ah	12V-20Ah

Maintenance record

Copies of work orders and/or receipts for parts you purchase and install will be required to document maintenance done in accordance with the warranty. The chart below is printed only as a reminder to you that the maintenance work is required. It is not acceptable proof of maintenance work.

MAINTENANCEINTERVAL		DATE OF SERVICE	MILEAGE	SERVICING DEALER NAME AND ADDRESS	REMARKS
month	km(mi)				
1	1000(600)				
3	4000(2500)				
6	7000(4400)				
12	10000(6300)				
18	13000(8200)				
24	16000(10000)				
30	19000(12000)				
36	21000(13000)				
42	23000(14000)				
48	26000(16000)				
54	28000(17000)				
60	31000(19000)				

EMISSION RELATED COMPONENTS WARRANTY

Emission related components warranty

Your new BMS vehicle complies with the U.S. EPA, emission regulations. BMS Motorsports Inc. provides the emission warranty coverage for engines in the United States and its territories. In the remainder of this Emission Related components Warranty, BMS Motorsports Inc. will be referred to as BMS

Your warranty rights and obligations

U.S. EPA and BMS are pleased to explain the emission related components warranty on your 2022

ATV. New motor vehicles must be designed, built and equipped to meet State's stringent anti-smog standards. BMS must warrant the emission related components on your motorcycle for the periods of time listed below provided there has been no abuse, neglect or improper maintenance of your motorcycle.

Your emission related components may include parts such as the carburetor or fuel injection system, the ignition system, catalytic converter and engine computer, if it is equipped. Also included may be hoses, belts, connectors and other emission-related assemblies.

Where a warrantable condition exists, BMS will repair your motorcycle at no cost to you including diagnosis, parts and labor.

Manufacturer's warranty coverage

The 2022 and later model year ATV are warranted for 5000 km or for 5 years, whichever comes first. If any emission-related part on your vehicle is defective, the part will be repaired or replaced by BMS. This is your emission related components DEFECTS WARRANTY.

Owner's warranty responsibilities

As the vehicle owner, you are responsible for the performance of the required maintenance listed in your owner's manual. BMS recommends that you retain all receipts covering maintenance on your vehicle, but BMS cannot deny warranty solely for the lack of receipts or for your failure to ensure the performance of all scheduled maintenance.

You are responsible for presenting your vehicle to the BMS' dealer as soon as a problem exists. The warranty repairs should be completed in a reasonable amount of time, not to exceed 30 days.

As the vehicle owner, you should be aware that BMS may deny your warranty coverage if your vehicle or a part has failed due to abuse, neglect, improper maintenance or unapproved modifications.

If you use your vehicle in any type of competitive event, this warranty is immediately and completely void.

If you have any questions regarding your warranty rights and responsibilities, you should contact the following office.

BMS Motorsports, Inc
1151 Spruce Street Riverside, CA 92507
Tel :855-810-8877

Warranty coverage

BMS warrants that each new 2022 and later BMS motorcycles:

- A. is designed, built and equipped so as to conform at the time of initial retail purchase with all applicable regulations of the United States Environmental Protection Agency, and the California Air Resources Board; and
- B. is free from defects in material and workmanship which cause such vehicle to fail to conform with applicable regulations of the United States Environmental Protection Agency or the California Air Resources Board for the periods specified above.

The emission related components warranty period for this vehicle begins on the date the vehicle is delivered to the first purchaser other than an authorized dealer, or the date it is first used as a demonstrator, lease, or company vehicle, whichever comes first and continues for the period of time listed above. This warranty is transferable to each subsequent purchaser for the duration of the warranty period.

Warranty repairs will be made without charge for diagnosis, parts, or labor. All defective parts replaced under this warranty become the property of BMS. A list of warranted parts is included in this warranty statement. Normal maintenance items, such as spark plugs and filters, that are on the warranted parts list are warranted up to their required replacement interval only.

Only BMS approved replacement parts may be used in the performance of any warranty repairs and must be provided without charge to the owner. The use of replacement parts not equivalent to the original parts may impair the effectiveness of your engine emission related components. If such a replacement part is used in the repair or maintenance of your engine, and an

authorized BMS dealer determines it is defective or causes a failure of a warranted part, your claim for repair of your engine may be denied. If the part in question is not related to the reason your engine requires repair, your claim will not be denied.

To obtain warranty service

You must take your BMS Vehicle, along with your sales receipt or other proof of original purchase date, at your expense, to any BMS dealer who is authorized by BMS to sell and service that BMS product during his normal business hours. Claims for repair or adjustment found to be caused solely by defects in material or workmanship will not be denied because the vehicle was not properly maintained and used.

Repair or replacement of any warranted part is performed at no charge at a warranty station, except in an emergency situation. An emergency occurs when a warranted part or a warranty station is not reasonably available to the owner. In an emergency, repairs may be performed at any available service establishment, or by any individual, using any replacement part. The manufacturer will reimburse the owner for the expenses, including diagnostic charges, not to exceed the manufacturer's suggested retail price for all warranted parts replaced and labor charges based on the manufacturer's recommended time allowance for the warranty repair and the geographically appropriate hourly labor rate. The owner may reasonably be required to keep receipts and failed parts in order to receive compensation. A part not available within 30 days, or a repair not complete within 30 days also constitutes an emergency.

If you are unable to obtain warranty service, or are dissatisfied with the warranty service you received, contact the owner of the dealership involved. Normally this should resolve your problem. However, if you require further assistance, write or call the BMS Motorsports Inc.

Customer Service Department.

Exclusions and limitations

This Emission Related components Warranty shall not cover any of the following:

A. Repair or replacement as a result of

(1) accident,

(2) misuse,

(3) repairs improperly performed or replacements improperly installed,

(4) use of replacement parts or accessories not conforming to BMS' specifications which adversely affect performance and/or

(5) use in competitive racing or related events.

B. Inspections, replacement of parts and other services and adjustments required for require maintenance.

C. Any vehicle equipped with an odometer or hour meter on which the odometer mileage or hour meter reading has been changed so that actual mileage cannot be readily determined.

Limited liability

A. The liability of BMS under this emission related components warranty is limited solely to the

remedying of defects in material or workmanship by an authorized BMS dealer at its place of business during customary business hours. This warranty does not cover inconvenience or loss of use of the vehicle or transportation of the vehicle to or from the BMS dealer. BMS shall not be liable for any other expenses, loss or damage, whether direct, incidental, consequential or exemplary arising in connection with the sale or use of or inability to use the vehicle for any purpose. Some states do not allow the exclusion or limitation of any incidental or consequential damages, so the above limitations may not apply to you.

- B. No express emission related components warranty is given by us except as specifically set forth herein. Any emission related components warranty implied by law, including any warranty of merchantability or fitness for a particular purpose, is limited to the express emission related components warranty terms stated in this warranty. The foregoing statements of warranty are exclusive and in line of all other remedies. Some states do not allow limitations on how long an implied warranty lasts so the above limitations may not apply to you.
- C. No dealer is authorized to modify this BMS Limited Emission Related components Warranty.

SYSTEMS COVERED BY THIS WARRANTY:	PARTS DESCRIPTION:
Engine Components-	Intake and exhaust valves, Drive belts, Manifold and cylinder head bolts, Engine oil and filter, Engine coolant, Cooling system hoses and connections
Fuel Metering	Fuel injector, ECM, Heated O2 sensor, Throttle position sensor, Intake air temp sensor
Evaporative	Fuel tank, Fuel cap, Fuel hoses
Exhaust	Catalytic Convertor
Air Induction	Air filter housing, Air filter element*, Air injection valve
Ignition	Ignition coil assembly, Ignition control module, Spark plug cap, Spark plug*
Crankcase Emission Control	Crankcase breather tube
Miscellaneous Parts	Tubing, fittings, seals, gaskets, and clamps associated with these listed systems.

California emission control warranty statement

Your warranty rights and obligations

The California Air Resources Board and BMS Motorsports Inc.(herein and after "BMS") are pleased to explain the emission control system warranty on your 2022 sport vehicle. In Caledonia, new off-highway recreational vehicles must be designated, built and equipped to meet the State's stringent anti-smog standards. BMS must warrant the emission control system on your sports vehicle for the periods of time listed below provided there has been no abuse. Neglect or improper maintenance of your sport vehicle

Your emission control system may include parts such as the carburetor or fuel injection system, fuel tank, fuel hoses carbon canister, and engine computer. Also included may be hoses, belts. Connectors and other emission-related assemblies. Where a warrantable condition exists. BMS will repair your sport vehicle at no cost to you including diagnosis, parts and labor.

Manufacturer's warranty coverage

The 2022 and later model veer sport vehicles

For 30 months, or 2500 miles, or 250 hours, whichever comes first, except for evaporative components over the OHRV high-priced warranty value, which is covered for 60 months, or 5000 miles, or 500 hours, whichever comes first. If any emission-related part on your vehicle is defective, the part will be repaired or replaced by BMS.

Owner's warranty responsibilities

As the sport vehicle owner, you are responsible for the performance of the required maintenance listed in your owner's manual. BMS recommends that you retain all receipts covering maintenance on your sport vehicle, but BMS cannot deny warranty solely for the lack of receipts or for your failure to ensure the performance of all scheduled maintenance.

You are responsible for presenting your sport vehicle to the BMS' dealer as soon as a problem exists. The warranty repairs should be completed in a reasonable amount of time, not to exceed 30 days.

As the sport vehicle owner, you should be aware that BMS may deny your warranty coverage if your sport vehicle or a part has failed due to abuse, neglect, improper maintenance or unapproved modifications.

If you have any questions regarding your warranty rights and responsibilities, you should contact the following office.

BMS Motorsports Inc.

1151 Spruce Street, Riverside, CA 92507

Tel: 951-274-9267

California Air Resources Board

9528 Telstar Avenue

El Monte, CA 91731

Warranty coverage

BMS warrants that each new 2018 and later BMS sports vehicle:

- A. is designed, built and equipped so as to conform at the time of initial retail purchase with all applicable regulations of the California Air Resources Board: and
- B. is free from defects in material and workmanship which cause such vehicle to fail to conform to applicable regulations of the California Air Resources Board for the periods specified above.

The emission related components warranty period for this vehicle begins on the date the vehicle is delivered to the first purchaser other than an authorized dealer, or the date it is first used as a demonstrator, lease, or company vehicle, whichever comes first and continues for the period of time listed above. This warranty is transferable to each subsequent purchaser for the duration of the warranty period.

Warranty repairs will be made without charge for diagnosis, parts, or labor. All defective parts replaced under this warranty become the property of BMS. A list of warranted parts is included in this warranty statement. Normal maintenance items. Such as spark plugs and filters that are on the warranted parts list are warranted up to Thiel required replacement interval only.

Only BMS approved replacement parts may be used in the performance of any warranty repairs and must be provided without charge to the owner. The use of replacement parts not equivalent to the original parts may impair the effectiveness of your engine emission related components.

If such a replacement part is used in the repair or maintenance of your engine. and an authorized BMS dealer determines it is defective or causes a failure of a warranted part, your claim for repair of your engine may be denied. If the part in question is not related to the reason your engine requires repair, your claim will not be denied.

To obtain warranty service

You must take your BMS sports vehicle, along with your sales receipt or other proof of original purchase date, at your expense, to any BMS dealer who is authorized by BMS to sell and service that BMS product during his normal business hours. Claims for repair or adjustment found to be caused solely by defects in material or workmanship will not be denied because the vehicle was not properly maintained and used.

Repair or replacement of any warranted part is performed at no charge at a warranty station, except in an emergency situation. An emergency occurs when a warranted part or a warranty station is not reasonably available to the owner In an emergency, repairs may be performed at any available service establishment. or by any individual. using any replacement part. The manufacturer will reimburse the owner for the expenses. Including diagnostic charges, not to exceed the manufacturer's suggested retail price for all warranted parts replaced and labor charges based on the manufacturer's recommended time allowance for the warranty repair and the geographically appropriate hourly labor rate. The owner may reasonably be required to keep receipts and failed parts in order to receive compensation. A part not available within 30 days. or a repair not complete within 30 days also constitutes an emergency.

If you are unable to obtain warranty service, or are dissatisfied with the warranty service you received, contact the owner of the dealership involved. Normally this should resolve your problem. However, if you require fur the assistance, write or call the BMS Motorsports Inc. Customer Service Department.

Exclusions and limitations

This Emission Related components Warranty shall not cover any of the following:

A. Repair or replacement as a result of

(1) accident,

(2) misuse,

(3) repairs improperly performed or replacements improperly installed

(4) use of replacement parts or accessories not conforming to BMS' specifications which adversely affect performance and/or

(5) use in competitive racing or related events.

B. Inspections, replacement of parts and other services and adjustments required for required maintenance.

C. Any vehicle equipped with an odometer or hour meter on which the odometer mileage or hour meter reading has been changed so that actual mileage cannot be readily determined.

Limited liability

- A. The liability of BMS under this emission related components warranty is limited solely to the remedvina of defects in material or workmanship by an authorized BMS dealer at its place of business during customary business hours. This warranty does not cover inconvenience or loss of use of the vehicle or transportation of the vehicle to or from the BMS dealer. BMS shall not be liable for any other expenses. loss or damage, when he direct. incidental. consequential or exemplarv arising in connection with the sale or use of or inability to use the vehicle for any purpose. Some states do not allow the exclusion or limitation of any incidental or consequential damages, so the above limitations may not apply to you.
- B. No express emission related components warranty is given by us except as specifically set forth herein. Any emission related components warranty implied by law, including any warranty of merchantability or fitness for a particular purpose, is limited to the express emission related components warranty terms stated in this warranty. The foregoing statements of warranty are exclusive and in line of all other remedies. Some states do not allow limitations on how long an implied warranty lasts so the above limitations may not apply to you.
- C. No dealer is authorized to modify this BMS Limited Emission Related components Warranty

SYSTEMS COVERED BY THIS WARRANTY:	PARTS DESCRIPTION:
Evaporative	Fuel tank, Fuel cap, Fuel hoses, Canister

⚠ WARNING

Improper ATV use can result in SEVERE INJURY or DEATH





ALWAYS USE AN APPROVED HELMET AND PROTECTIVE GEAR

NEVER USE ON PUBLIC ROADS

NEVER CARRY PASSENGERS

NEVER USE WITH DRUGS OR ALCOHOL

NEVER operate:

- without proper training or instruction.
- at speeds too fast for your skills or the conditions.
- on public roads-a collision can occur with another vehicle.
- with a passenger-passengers affect balance and steering and increase risk of losing control.

ALWAYS:

- use proper riding techniques to avoid vehicle overturns on hills and rough terrain and in turns.
- avoid paved surfaces-pavement may seriously affect handling and control.

**LOCATE AND READ OWNER'S MANUAL
FOLLOW ALL INSTRUCTIONS AND WARNINGS.**

370310828

TYPE I

⚠ WARNING

Improper ATV use can result in SEVERE INJURY or DEATH





ALWAYS USE AN APPROVED HELMET AND PROTECTIVE GEAR

NEVER USE ON PUBLIC ROADS

NEVER CARRY MORE THAN 1 PASSENGERS

NEVER USE WITH DRUGS OR ALCOHOL

NEVER operate:

- without proper training or instruction.
- at speeds too fast for your skills or the conditions.
- on public roads-a collision can occur with another vehicle.
- with a passenger-passengers affect balance and steering and increase risk of losing control.

ALWAYS:

- use proper riding techniques to avoid vehicle overturns on hills and rough terrain and in turns.
- avoid paved surfaces-pavement may seriously affect handling and control.
- reduce speed and use extra caution at all times when carrying a passenger-dismount passenger when conditions require.
- make sure passenger reads and understands this label and passenger safety label.

**LOCATE AND READ OWNER'S MANUAL
FOLLOW ALL INSTRUCTIONS AND WARNINGS.**

370310956

TYPE II